

Toray UF

Instruction Manual



“TUF Rack series”
<Rack-Integrated Toray UF>

TORAY
Innovation by Chemistry

Notice

The data and information contained in this document are based upon rigorous technical testing by Toray, and is to the best of our knowledge reliable. Toray cannot control design and operating conditions, and consequently Toray does not assume any liability for results obtained or damage incurred through the application of the information provided herein. No liability, warranty or guarantee of final product performance by Toray is implied by the information provided in this document.

This manual supersedes all previous versions. Technical modification of products or production technology may necessitate changes to information in this manual without prior notice. Please verify that your version of the manual is the latest version available by either contacting Toray, or checking online at www.water.toray.

Terms and Conditions of Use

When using this document, please read the Terms and Conditions of Use below thoroughly and agree to them before using this document. By using this document, you agree to all of the Terms and Conditions of Use outlined here. The Terms and Conditions of Use are subject to change without prior notice, so please check with Toray for the latest Terms and Conditions of Use before using the document.

1. Intellectual Property Rights

The content in this document is protected by copyright laws in respective countries and relevant treaties. Accordingly, the document's information may not be reproduced, altered, or distributed without permission in writing from Toray. We permit downloading this document through Toray's website as a PDF file, stored on a personal computer, and printed out for customers' personal use. However, we prohibit transferring this document to any other websites or printed media. The material contained in this document may not be used without permission from the copyright holder for any other purpose that exceeds the scope permitted under copyright law.

2. Trademarks

The "TORAY" company name used in this document is a trade name, and the names of products manufactured by Toray are trademarks or registered trademarks. Toray's trade names and trademarks are protected under the Japanese Trademark Law, the Unfair Competition Prevention Law, and other legislation. The trade name and trademarks may not be used or reproduced without express permission from Toray.

3. Disclaimer

Toray takes all reasonable care in updating the information in this document. However, Toray makes no representation and warranty of any kind, either express or implied, including without limitation, any implied warranties concerning the accuracy, usefulness, suitability, or fitness for a particular purpose of the information in the document.

Toray shall not be responsible or liable for any losses or damage incurred due to the use of the information in this document. The information in this document is subject to change without prior notice, and Toray reserves the right to suspend or discontinue the publication of this document.

4. Availability of Goods and Services

The goods and services contained in this document are not available in all countries and regions. Goods and services may also be supplied under different trademarks in different countries. We ask that you contact your nearest Toray representative office if you wish to use the goods and services shown or implied in this document.

5. Proper Law and Court of Jurisdiction

This Terms and Conditions of Use shall be governed by and construed according to the laws of Japan. Any and all disputes arising out of or relating to this document shall be brought to the Tokyo District Court Tokyo, Japan.

Contact Information

Toray Industries, Inc. — UF & MBR Membrane Products Department (Global Headquarters)
Nihonbashi Mitsui Tower, 1-1, Nihonbashi-Muromachi 2 chome, Chuo-ku, Tokyo, 103-8666
Japan

Tel: +81-3-3245-4542 Fax: +81-3-3245-4913

Toray Membrane USA, Inc. (TMUS)
13435 Danielson Street, Poway, California 92064 USA
Tel: +1-858-218-2360 Fax: +1-858-218-2380

Toray Membrane Europe AG (TMEU)
Kaspar Pfeiffer-Strasse 4, CH-4142 Münchenstein, Switzerland
Tel: +41-61-415-8710 E-mail: info.tmeu.mb@mail.toray

Toray Asia Pte. Ltd. (TAS)
67 Ubi Ave 1, Starhub Green, # 04-12 Singapore 408942, Republic of Singapore
Tel: +65-6226-0525 E-mail: enquiry.tas.mb@mail.toray

Toray BlueStar Membrane Co., Ltd. (TBMC)
No. 28 Yu An Road, Shunyi District,, Beijing 101318, China
Tel: +86-10-8048-5216 Fax: +86-10-8048-5217

Toray Membrane Middle East LLC (TMME)
3515, 3rd Industrial City, 8682, Dammam, 34857, Kingdom of Saudi Arabia
Tel: +966-13-568-0091 Fax: +966-13-568-0093

Toray Advanced Materials Korea Inc. (TAK)
7, Magokdong-ro 10-gil, Gangseo-gu, Seoul 07790, Republic of Korea
Tel: +82-22-3279-1000 Fax: +82-2-3279-1411

website: www.water.toray

TABLE OF CONTENTS

I.	Introduction	
1.	Characteristics of Toray "HFUG series" Membrane Modules	5
2.	About "type HN"	5
3.	Applications of Toray "HFUG-2020HN" Membrane Module	5
4.	Toray UF TUF Rack <Rack-Integrated Toray UF>	6
II.	For Your Safety	
1.	Safety Instruction for Unpacking and Installation	7
2.	Safety Instruction for Filtration Operation	8
3.	Safety Instruction for Chemical Cleaning	10
4.	Safety Instruction for Disposal	11
5.	Warranty Claims	11
6.	Warranty Policy	11
III.	Specifications of Toray "HFUG-2020HN" for TUF Rack series	12
IV.	Configuration of Toray "HFUG-2020HN" Membrane Module	
1.	Configuration of Toray "Type HN" Membrane Module	15
2.	Configuration of "Toray UF TUF Rack"	16
3.	Shipping and Handling	20
V.	Installation	
1.	Assembly and Maintenance	20
2.	Disassembly and Disposal	39
VI.	Operation	
1.	Filtration	40
2.	Backwash and Air-scrubbing	41
3.	Toray Maintenance Cleaning	44
4.	Basic Trans-Membrane Pressure Calculation	46
5.	Temperature Correction Factor	47
6.	Performance Recording	47
VII.	Chemical Cleaning	48
VIII.	Storage of Membrane Module	
1.	Storage of New Membrane Modules	51
2.	Storage of Membrane Modules and Racks after Use	51
3.	Replace Preservative Solution	52
IX.	Appendix	52

I. Introduction

Toray PVDF Hollow Fiber Membrane Module "HFUG-2020HN " is a pressurized hollow fiber UF (Ultra Filtration) membrane module developed with polymer science and membrane fabrication technologies accumulated over decades of successful membrane manufacturing at Toray Industries, Inc.

The membrane material is Polyvinylidene fluoride (PVDF). The nominal pore size of the membrane is 0.01 micrometers.

The module, which is permanently potted in its casing, is pressure-driven, providing filtrate quality equal to that of submerged modules while allowing for a wider range of transmembrane pressure (TMP) for more flexible plant operation. The maximum operating pressure is 600 kPa (87.0 psi). The flow direction is outside-in, which is more suitable for higher turbidity water treatment because of the air-scrubbing effectiveness. Additionally, outside-in modules can remove suspended solids more effectively at higher recovery rates compared to inside-out fibers.

1. Characteristics of Toray "HFUG series" Membrane Modules

(1) High Filtration Flux

HFUG series provides high filtration flux and stable operation for the filtration of various raw water sources. The membrane is made with a special spinning method, which enables high permeability and high fouling resistance.

(2) Excellent Water Quality

HFUG series provides very good water quality for the filtrate, extremely low turbidity since the membrane has a nominal pore size of 0.01 micrometers. HFUG series is recommended to be applied to the tertiary treatment of sewage water and RO pretreatment in desalination.

(3) High Mechanical Strength

The membrane of HFUG series has very high mechanical strength because it is made of PVDF with the special spinning method developed by Toray. HFUG series provides high integrity and durability under recommended operating conditions.

(4) High Chemical Durability

The membrane material of HFUG series is PVDF, which allows to clean the membrane with high concentrations of chlorine and with high concentrations of acid resulting in better cleaning and longer sustainable membrane flux rates.

2. About "type HN"

"Type HN" is a module type which allows high pressure (600 kPa) operation, whose housing is sealed with an improved cap. All connecting parts of "Type HN" modules are optimized to allow operation under the high pressure.

3. Applications of Toray "HFUG-2020HN" Membrane Module

- Tertiary Treatment
- RO Pretreatment
- Industrial Water Production
- Reuse of Industrial Wastewater



4. Toray UF TUF Rack <Rack-Integrated Toray UF>

Pre-engineered, standardized rack design specialized for Toray UF modules to significantly reduce engineering design and installation costs.



- Highly reliable Toray UF membrane
- The same operation procedure as the Toray UF module
- Compact piping arrangement, which saves engineering and reduces installation footprint
- Shipped unassembled for easy transportation and lower shipment cost

II. For Your Safety

- Please be sure to read and follow the instructions below before using HFUG-2020HN. This manual should be retained for future reference.
- Follow the safety precautions as they are intended to protect operators and equipment from various risks such as physical harm and/or property damage. The following table shows a level of potential risk for each indicated symbol.

 DANGER	This symbol indicates an imminent hazardous situation which will result in serious injury or death when the instruction is not observed.
 WARNING	This symbol indicates a potentially hazardous situation which will result in serious injury or death when the instruction is not observed.
 CAUTION	This symbol indicates a potentially hazardous situation which might result in injury or property damage when the instruction is not observed.

- The following table explains the information to be noted

 Prohibited	"Prohibited" This symbol indicates a prohibited action or procedure.
 Instruction	"Instruction" This symbol indicates an important action or procedure which has to be taken without fail.

1. Safety Instruction for Unpacking and Installation



DANGER



Instruction

Use equipment such as chain blocks, a crane, or a forklift truck when handling the module. The module is too heavy to handle by hand.



Instruction

Be sure to wear safety gear such as rubber gloves and safety glasses when unpacking. The membrane is packaged in sodium hypochlorite solution (Max. 200 mg/L as Cl_2). If the solution happens to splash onto the skin, wash the affected part with running water. If the solution happens to get in the eyes or mouth, wash the affected part with sufficient amounts of clean running water for more than 15 minutes and see the doctor immediately.



WARNING



Instruction

Be sure to wear safety gear such as a helmet to protect your head and safety shoes to avoid injury due to falling of related parts or equipment, such as module, etc.



Instruction

Be sure to wear protective appropriate gloves to avoid injury of hands by the package box of the modules.



Prohibited

Do not drink the preservative solution in the membrane module.



Instruction

When connecting or disconnecting the modules to or from the piping, be sure to secure a sufficient work area, and take care not to catch and hurt fingers.

 **CAUTION**

Instruction

The preservative solution should be drained out before using the modules. After that, fill tap water or equivalent quality water into the modules to prevent the hollow fiber membrane from drying out. Do not allow the modules to dry even for a few hours.



Prohibited

The membrane modules should not be frozen.



Prohibited

Be careful not to damage or dent the modules and the assembly parts during handling.



Instruction

Housing Joints and screws are applied to connect the modules of HFUG-2020HN to the piping. Follow the instruction of the connection provided by the supplier at the connection point. Wrong connections may damage the modules.



Prohibited

Keep the connection surface free of any dirt or oils.



Instruction

Be sure to install the modules and the Long Elbow vertically for effective air scrubbing and leak prevention.

2. Safety Instruction for Filtration Operation

 **DANGER**

Prohibited

Do not exceed the maximum applicable pressure of 600 kPa (87.0 psi). Higher pressures can damage the modules, the assembly parts, and the connections between the parts.



Instruction

Flush the modules at low pressure, filling from the bottom, and vent to remove any air from the modules. Air left in the modules may cause water hammer and may result in damage to the membrane.

WARNING

Instruction

Confirm that the preservative solution in the modules is completely drained out before starting the filtration operation. The preservative solution is harmful to humans.



Prohibited

The filtrate water should not be used for drinking water production.



Instruction

Make sure air tubes or connected pipes are properly fixed. Otherwise, the tubes or connected pipes may be blown away or behave violently during air-scrubbing.



Prohibited

Do not exceed the maximum temperature of 40 deg C (104 deg F). The higher temperature damages the modules, the assembly parts, and the connections between the parts.

CAUTION

Instruction

Flush all the piping out with clean water and make sure no debris is remaining in the piping prior to connecting the modules.



Instruction

Prior to use, make certain modules are flushed. Filtrate water should be drained unless it meets the required quality.



Instruction

Protect modules and assembly parts from direct sunlight and ultraviolet light. Ultraviolet light can degrade the module housings, assembly parts, and membranes.



Instruction

Constantly monitor filtrate water quality such as turbidity and/or the number of particles during filtration, and stop the operation if abnormal water quality is detected.

Do not overfeed air to the modules. Excessive scrubbing air damages the membranes and/or shortens the membrane life.



Instruction

The air flow rate should be within the range below for each module.

HFUG-2020HN: 4.8 – 9.0 Nm³/h (2.8 – 5.3 scfm)

The maximum required air pressure during the air-scrubbing for the inside of the rack will be 40 kPa (6 psi).



Prohibited

Do not freeze the membrane modules.



Instruction

The operating conditions, including the filtration flux and the periodical physical cleaning, must be properly set up otherwise the trans-membrane pressure may rise too quickly. The operation range is described in the latter section of this manual.

3. Safety Instruction for Chemical Cleaning

**DANGER**

Prohibited

Do not mix sodium hypochlorite with acid. Such mixture generates toxic chlorine gas.

**WARNING**

Instruction

Take special precautions when handling chemicals during chemical cleaning. Wear the safety gear such as safety glasses and protective appropriate gloves. If chemicals come in direct contact with your skin or your clothes, treat the contacted part appropriately based on the SDS.



Instruction

Stop operation whenever any anomaly occurs with the equipment or any signs of an anomaly are observed.



Instruction

In the chemical cleaning, strictly follow the procedure described in the latter section of this manual. Otherwise you may damage the modules or negatively affect the membrane performance.

4. Safety Instruction for Disposal



WARNING



Instruction

Apply a service of a qualified waste disposing company when disposing of the modules. Use the appropriate facilities in which hydrogen fluoride (HF) gas can be neutralized when the module is to be incinerated. HF gas is generated with the incineration of membrane.

5. Warranty Claims

UF rack shall be delivered as parts in dismantled condition.

UF modules and UF rack parts that are damaged due to improper loading, shipping, handling, or storing shall not be covered by Toray Industries, Inc.'s warranty. Therefore, it is very important that the customer firmly follows the instructions of loading, shipping, handling, and storing of the UF modules mentioned in this Instruction Manual.

UF modules which are in their original sealed package can be stored for 12 months from the date they were shipped from Toray's factory or warehouse. If they are stored for longer than 12 months, the warranty will become void unless otherwise Toray Industries, Inc. agrees.

Toray Industries, Inc. shall only warrant the quality of UF rack parts, not assembled UF rack, thus the customer firmly follows procedures of UF rack assembly mentioned in this Instruction Manual under customer's responsibility. Any UF rack troubles such as leakage, distortion, collapsing, parts damages, or unbalanced water and/or chemical distribution in the UF rack due to improper assembly shall not be covered by Toray Industries, Inc.'s warranty.

6. Warranty Policy

Full and proper compliance with this Instruction Manual is a mandatory required thing for the claims under the warranty. In case of making a warranty claim, the customer automatically agrees to provide Toray Industries, Inc. with the information about operation mode, recording performance data of UF systems.

Kindly please contact Toray Industries, Inc. if the customer wishes to deviate from any of the procedures or specifications mentioned in this Instruction Manual and request written approval in advance. Otherwise, the customer has a risk of invalidation for any warranty claims that they may make in the future.

III. Specifications of Toray "HFUG-2020HN" for TUF Rack series

Table 1. Specifications of Membrane *1)

Membrane Material		PVDF (Polyvinylidene fluoride)
Nominal Pore Size *2)		0.01 micrometers
Trans-Membrane Pressure (TMP)	Maximum *3)	300 kPa (43.5 psi)
	Normal Operation	Lower than 200 kPa (29.0 psi)
Storage and Operating Temperature Range		1 – 40 deg C (32 – 104 deg F)
Operating pH Range		1 – 10

*1): Note that the specifications are subject to change without notice.

*2): Estimation from removal of model particles.

*3): TMP (Trans-Membrane Pressure) should be below 300 kPa (43.5 psi) at any time even during the filtration.

Table 2. Feed Water Limits *1), *2)

Turbidity	Intermittent Peak *3)	200 NTU
	Continuous Maximum	50 NTU
TSS	Intermittent Peak *3)	200 mg/L
	Continuous Maximum	50 mg/L
Ozone		Not detected
Pretreatment Filter Mesh Size		Smaller than 200 micrometers
Temperature Range		1 – 40 deg C (34 – 104 deg F)
pH Range		1 – 10
Maximum Feed Pressure		600 kPa (87.0 psi)

*1): Note that the specifications are subject to change without notice.

*2): If you have any concerns about design, please contact us.

*3): The duration time should be less than 48 hours and the occurrence frequency should not exceed more than once a month.

 WARNING	Maximum Feed Pressure is 600 kPa, but the allowable range of TMP is 200 kPa (Normal) to 300 kPa (Maximum)
--	---

Table 3. Cleaning Limits *1)

Cleaning pH Range	0 – 12
Cleaning Temperature Range	1 – 40 deg C (34 – 104 deg F)
Maximum Concentration of NaClO as Cl ₂	3,000 mg/L (10 ≤ pH ≤ 12)
Maximum NaClO Exposure (Lifetime contact time) as Cl ₂	1,000,000 mg/L hours
Maximum Acid Contact Time	1,000 hours (pH ≥ 0)

*1): Note that the specifications are subject to change without notice.

Table 4. Specifications of Module *1)

Module Type		HFUG-2020HN
Membrane Surface Area (Outer Surface)		90 m ² (969 ft ²)
Dimensions	Diameter	216 mm (8.50 inches)
	Length	2,160 mm (7.087 ft.)
Weight	Full of Water	103 kg (227 lbs)
	Drained	65 kg (143 lbs)
Materials	Housing	PVC and/or equivalent
	Potting	Epoxy and/or equivalent
Connections	Top	Housing Joint 80A
	Bottom	Housing Joint 80A
	Side	Housing Joint 65A
Operating Conditions	Filtration Method	Outside to inside, dead end
	Max. Inlet Pressure	600 kPa (87.0 psi)
	Max. Temperature	40 deg C (104 deg F)

*1): Note that the specifications are subject to change without notice.



CAUTION

- Handle and operate the modules within the ranges and the limits indicated in Table 1 to 4. Operation out of these ranges or limits may damage the modules and affect filtration performance.

Table 5. Specifications of Toray UF TUF Rack *1)

Item			Toray UF TUF Rack		
Connections*2) *3)			Header-1#1 (Top header)	PVC TS Flange 10K 150A (JIS B2220)	
			Header-1#2 (Bottom header)	PVC TS Flange 10K 150A (JIS B2220)	
			Manifold	PVC TS Flange 10K 150A (JIS B2220)	
			Air Pipe	PVC TS Flange 10K 50A (JIS B2220)	
Operating Conditions			Max. TMP *4)	300 kPa (43.5 psi)	
			TMP for Normal operation	Lower than 200 kPa (29.0 psi)	
			Max. Inlet Pressure	600 kPa (87.0 psi)	
			Maximum Temperature	40 deg C (104 deg F)	
Array		No. of Modules	Max. Feed Water Flow	Max. Backwash Flow	Max. Air Flow
L	W	[EA]	m ³ /h (gpm)	m ³ /h (gpm)	Nm ³ /h (scfm)
2	2	4	61 (266)	67 (293)	36 (22)
3	2	6	91 (398)	100 (437)	54 (33)
4	2	8	122 (533)	134 (586)	72 (44)
5	2	10	152 (665)	168 (735)	90 (56)
6	2	12	183 (800)	201 (879)	108 (67)
7	2	14	213 (931)	235 (1,028)	126 (78)
8	2	16	214 (936)	236 (1,032)	144 (89)
9	2	18	214 (936)	236 (1,032)	162 (100)
10	2	20	214 (936)	236 (1,032)	180 (112)
11	2	22	214 (936)	236 (1,032)	198 (123)
12	2	24	214 (936)	236 (1,032)	216 (134)
13	2	26	214 (936)	236 (1,032)	234 (145)
14	2	28	214 (936)	236 (1,032)	252 (157)

*1): Note that the specifications are change without notice.

*2): Flange gaskets are not included in the parts supplied by Toray.

*3): Refer to the appendix for detailed dimensions and nozzle list.

*4): TMP (Trans-Membrane Pressure) should be below 300 kPa (43.5 psi) at any time.

IV. Configuration of Toray "HFUG-2020HN" Membrane Module

1. Configuration of Toray "Type HN" Membrane Module

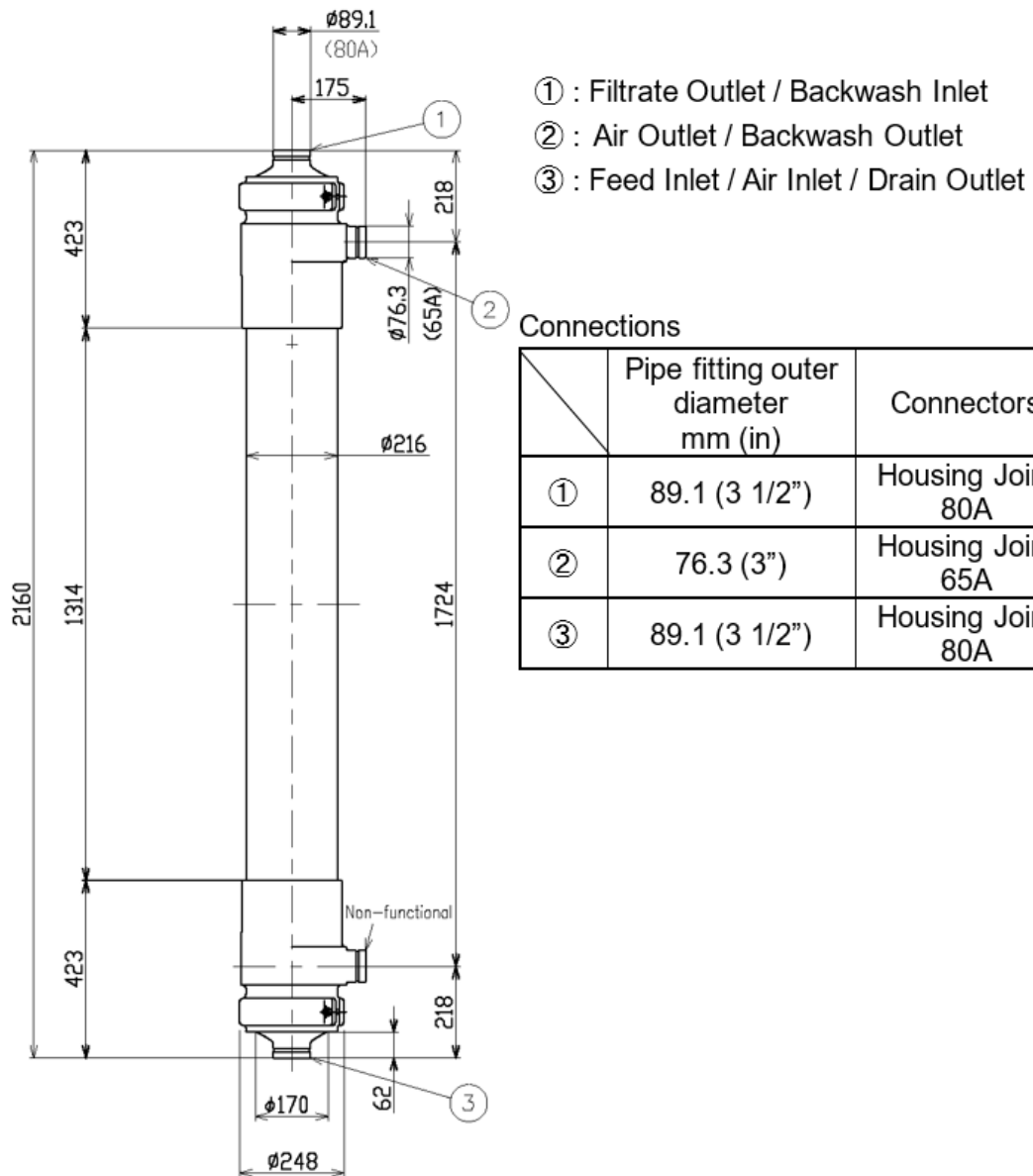

Fig. 1. Type: HFUG-2020HN

2. Configuration of “Toray UF TUF Rack”

Table 6. Configurations with 2 Rows of Modules *1) *2)

Array		No. of Modules	Total Membrane Area	Rack Length	Rack Width	Rack Height	Weight	
L	W	[EA]	[m ²]	[mm]	[mm]	[mm]	Full of Water [kg]	Drained [kg]
2	2	4	360	810	730	2,880	620	400
3	2	6	540	1,130	730	2,880	910	590
4	2	8	720	1,450	730	2,880	1,210	780
5	2	10	900	1,770	730	2,880	1,500	960
6	2	12	1,080	2,090	730	2,880	1,800	1,150
7	2	14	1,260	2,420	730	2,880	2,100	1,350
8	2	16	1,440	2,740	730	2,880	2,400	1,540
9	2	18	1,620	3,060	730	2,880	2,700	1,730
10	2	20	1,800	3,380	730	2,880	3,000	1,920
11	2	22	1,980	3,700	730	2,880	3,280	2,100
12	2	24	2,160	4,020	730	2,880	3,570	2,290
13	2	26	2,340	4,330	730	2,880	3,860	2,480
14	2	28	2,520	4,660	730	2,880	4,160	2,670

*1): Note that the specifications are subject to change without notice.

*2): Refer to the appendix for detailed dimensions and nozzle list.

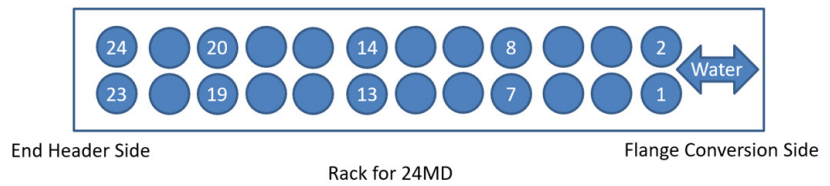
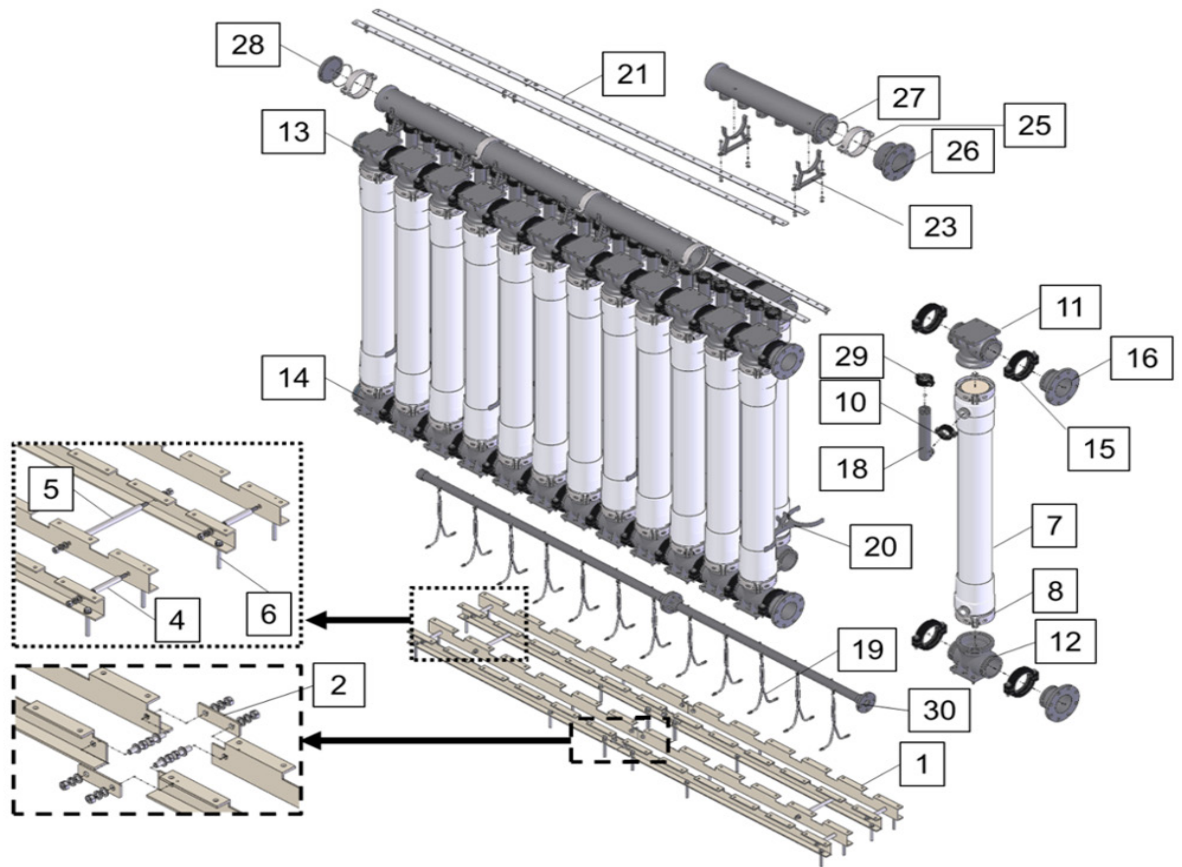

Fig. 2. "Toray UF TUF Rack" Modules and Components

Table 7. Parts List of “Toray UF TUF Rack” *1)

	Part Name	Description	Qty*2)	Notes*3)
1	Base Channel	Base Channel 6MD-R	4	CS, 18 kg/EA, 100 x 50 x 1,870 mm
		Base Channel 6MD-L	4	CS, 18 kg/EA, 100 x 50 x 1,870 mm
2	Base Channel Connector		4	CS, 50 x 6 x 160 mm
3	Hexagon Bolt Set for Base Channel Connector	Bolt, Nut M16	8	316SS, M16 x 40 mm
		Washer M16	16	
		Spring Washer M16	8	
4	Base Channel Stick-S set	Base Channel Stick-S	8	316SS, φ26 x 210 mm
		Hexagon Nut M16	16	316SS
		Washer M16	16	
		Spring Washer M16	16	
5	Base Channel Stick-L set	Base Channel Stick-L	4	316SS, φ26 x 370 mm
		Hexagon Nut M16	8	316SS
		Washer M16	8	
		Spring Washer M16	8	
6	Anchor Bolt	Customer's Scope	24	316SS, M16 x 185 mm
7	UF Module	UF Module	24	HFUG-2020HN
8		V-band for Module	48	316SS, 200A
9		O-ring for Module	48	EPDM, G200
10		Housing Joint 65A	24	Nylon, 65A
11	Header-1#1	Top Header	22	PVC, 150A, 8 kg/EA
12	Header-1#2	Bottom Header	22	PVC, 150A, 8 kg/EA
13	Top End Header		2	PVC, 150A, 8 kg/EA
14	Bottom End Header	Bottom End Header (R-side)	1	PVC, 150A, 8 kg/EA
		Bottom End Header (L-side)	1	PVC, 150A, 8 kg/EA

	Part Name	Description	Qty ^{*2)}	Notes ^{*3)}
15	Housing Joint DN150		48	Nylon, DN150
16	Flange Conversion	For Header	4	PVC, 150A
17	Hexagon Bolt Set for Base Channel	Bolt, Nut M12	96	316SS, M12 X 55 mm
		Washer M12	192	
		Spring Washer M12	96	
18	Long Elbow		24	PVC, 65A
19	Air Tube		24	PU, φ10 x 700 mm
20	Central Fixture		4	PVC
21	Flat Bar for Header	Flat Bar 4MD1H	4	CS, 50 x 6 x 1,350 mm
		Flat Bar 7MD2H	4	CS, 50 x 6 x 2,400 mm
22	Hexagon Bolt Set for Flat Bar	Bolt, Nut M12	28	316SS, M12 X 55 mm
		Washer M12	56	
		Spring Washer M12	28	
23	Manifold Base		8	PVC
24	O-ring for Manifold		5	EPDM, G175
25	V-band for Manifold	Original Connection	5	316SS
26	Flange Conversion	For Manifold	1	PVC, JIS/150A
27	Manifold	Manifold (6 holes)	4	PVC, 16 kg/EA
28	Manifold Stopper		1	PVC
29	Housing Joint 65A		24	Nylon, 65A
30	Air Pipe Set	Air Pipe 12MD-S	1	PVC, 50A x 1,930 mm
		Air Pipe 12MD-L	1	PVC, 50A x 2,050 mm
31	Hexagon Bolt Set for Air Pipe	Bolt, Nut M16	4	316SS, M16 X 65 mm
		Washer M16	8	
		Spring Washer M16	4	

*1): Note that the specifications are subject to change without notice.

*2): Quantity of parts of Toray UF TUF Rack with 24 modules (2 rows X 12 modules).

*3): Weights of parts that are considered heavy in handling is noted.

3. Shipping and Handling

(1) UF Modules Package

One UF Modules Package contains 10 modules. The UF Modules Package is the following size and weight.

Package for UF Modules: L 2,270 mm * D 1,190 mm * H 1,230 mm,
approximately 630 kg/box

The UF Modules Package can be stacked up to two tiers, and they should be stored in a cool place out of direct sunlight and avoid freezing or getting wet.

(2) Rack Parts Package

A package for Rack Parts is described in the Parts List (see Table 7).

Rack Parts Package Type 1: L 2,170 mm * D 1,080 mm * H 520 mm,
approximately 230 kg/box

The Rack Parts Package can be stacked up to five tiers, and they should be stored in a cool place out of direct sunlight and avoid freezing or getting wet in the same way as the UF Modules Package.

The size and weight of the Rack Parts Package above is for 24 modules. The number of parts and the weight of the Package will be changed as the number of modules is changed. If the rack is not a 24-module rack, please contact us regarding the package.

V. Installation

1. Assembly and Maintenance

Always operate with a calculated number of workers when a module needs to be lifted and placed on a Base Channel. The customer needs to determine the required number of workers in accordance with the situation. Toray recommends workers who are capable of properly handling heavy objects and have experience in assembly work under the local regulations and rules.

In this manual, the lifting work was operated by four workers. For setting up each module, more than two workers are required. One must hold the module vertical while the others fix the module to a Base Channel.

Also, the water supply side is described as the Flange Conversion side, and the end of the rack is described as the End Header side (see Fig. 2, p.17). The numbering of the modules begins with the left module on the Flange Conversion Side, and the number increases from left to right and from the Flange Conversion Side to the End Header Side.

**DANGER**

- Determine the maximum load permissible to a worker considering the applicable local laws and safety regulations and always pay attention to it. Excessive load can result in serious lower back injuries.
- The UF module and rack parts are quite heavy, not only the housing box but also each module and rack parts. If workers need to handle the housing box manually without proper equipment such as a crane or a forklift truck, assign enough workers in compliance with the local regulations.
- Use equipment such as chain blocks, a crane, or a forklift truck when handling the module. The HFUG-2020HN module is too heavy to handle by hand.
- Set up a scaffold in advance when assembling and installing “Toray UF TUF Rack”. Never climb the rack. Use protective equipment to ensure the safety of workers.
- Do not drop the module and the parts.
- When tightening or loosening any connections of modules and assemble parts, keep holding the module and the parts in position to prevent tipping and be careful not to be injured by hitting the body or clipping fingers.
- Make sure that the connection is established tension-free at any time.

**WARNING**

- Wear rubber gloves and safety glasses when draining the preservative solution, sodium hypochlorite solution (200 mg/L as Cl₂). If this solution splashes onto the skin, wash the affected part with running water. If the solution gets in eyes or mouth, wash the affected part with enough amounts of running water for over 15 minutes and see the doctor immediately.
- All work should be done in an area large enough to ensure safety.
- Secure a sufficient work area before working and be careful not to pinch fingers when tightening or loosening the rack.
- There should be at least 800 mm between racks to set up scaffolds for assembly work at the top of the racks.
- All product assembly and disassembly should be carried out in a safe, high-accessible location. The height of the product can be found in the assembly drawing in the Appendix.
- Make sure that pipes are properly fixed and correctly positioned so that center lines of each connected pipe are aligned.
- The floor on which the product is placed should be able to sustain the product's weight and vibration during operation.
- Be sure to wear safety gear when opening the sealed cap of a stored module. Open the cap with sufficient care to avoid blowing out the cap and storage solution.

**CAUTION**

- Be careful not to install the module upside down. Confirm the module is installed in the right direction.
- Do not allow the hollow fiber membranes and modules to dry even for a few hours, especially in summer. If the rack assembly process does not finish within the time, fill tap water or equivalent quality water into assembly rack and UF modules from feed water side such as upper side nozzle of UF module, and seal all openings (at least all air injection points and side openings of Header-1#2s) to prevent the hollow fiber membrane from drying out. Store the rack filled with water according to the storage method described in the later section.
- Do not freeze the module.
- Keep the connection surface free of any dirt or oils.
- To prevent leakage, keep the temperature of the work area and rack parts below 35°C when assembling the rack.
- Place the Base Channel on a level and stable ground. Make sure that stable connection is established in the correct position. Use the flexible joints prepared by the contractor as needed depending on the connection distance to the piping .

(1) Recommendation Tools List

Table 8. Recommendation Tool List of “Toray UF TUF Rack” *1)

Item	Spec	Qty (per worker)	Remark
Ratchet Wrench (or Wrench)	14 mm	2	Housing Joint 65A
Ratchet Wrench (or Wrench)	17 mm	2	V-band for Module V-band for Manifold
L Type Wrench (or Box Wrench)	19 mm	1	Base Channel Connector
Ratchet Wrench (or Wrench)	19 mm	2	Housing Joint DN150 Header-1#2 Bolts Header-1#2 Nuts Manifold Base Bolts Manifold Base Nuts
Ratchet Wrench (or Wrench)	22 mm	2	Housing Joint DN150
L Type Wrench (or Box Wrench)	24 mm	1	Base Channel Stick-S, Stick-L
Ratchet Wrench (or Wrench)	24 mm	2	Hexagon Bolt Set for Flat
Spirit Level		2	
Shim Plate	2 mm	1	To check V-band
Scaffold	Portable type Height: 1.7 m	Suitable amount	To access the top of membrane modules

*1): Note that the specifications are subject to change without notice.

In addition to the above list, tap water or equivalent quality water is required to prevent the hollow fiber membrane from drying out, which is used for filling into assembly rack and UF modules from feed water side such as upper side nozzle of UF module.

(2) Rack Assembly

The standard method to assemble the rack with a total of 24 modules in 2 rows and install the membrane modules is described below.

*[]: Parts List No. described in Table 7.

1. Unpack the membrane module and rack parts from package boxes.
2. Check the quantities of UF modules and rack parts with the list provided. Inspect the UF module and rack components for any defects or damages. Contact Toray officials if you find any mismatches in the number of the module and parts, defects, or damages.
3. Secure a work area to assemble Base Channels [1]. Take four pairs of Base Channel components out from the package boxes and put the components on the floor. Ensure to install the Base Channel horizontally on the floor. When installing the Base Channel, a Flange position of the piping side connecting to the Rack is correct.

4. Connect Base Channel 6MD-R [1] (1-1 and 1-2 (1), 2-1 and 2-2 (2)) with Base Channel Connectors [2], M16 Hexagon Bolt Sets [3]. The Base Channel Connector needs to be screwed on the outside of Base Channel.

Repeat this step for the Base Channel 6MD-L (3-1 and 3-2 (3), 4-1 and 4-2 (4)).

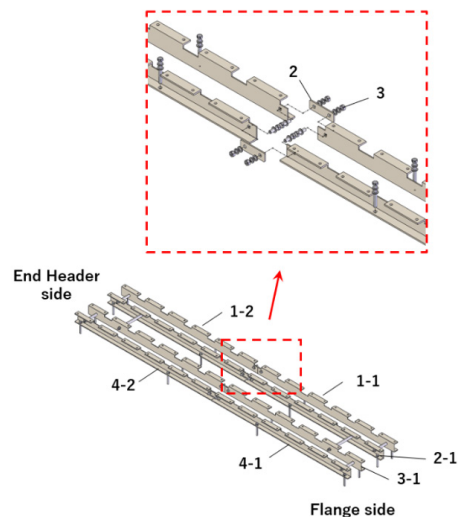

5. Assemble the Base Channel 6MD-R (1) and (2) with the Base Channel Stick-S[4], and also assemble the Base Channel 6MD-L (3) and (4).

Connect the Base Channel 6MD-R and 6MD-L with the Base Channel Stick-L [5].

When the assembling of the Base Channels is completed, check the horizontality of the Base Channels at all the positions with a spirit level.

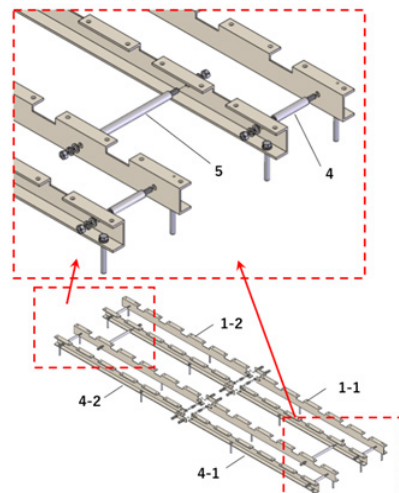

6. Set the assembled Base Channel at the planned position, and mark drill hole positions for Anchor Bolts. To check the installation position more precisely, place a bottom header with a Flange temporarily on the Base Channel, and make sure it can be connected to the Flange of the feed pipe to which it will be connected.

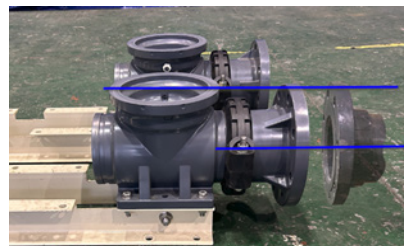

To avoid defects or damages caused by drilling holes, put the assembled Base Channel aside.

7. Drill holes for the anchors on the floor. During drilling, prevent any defects or damages to the assembled Base Channel. Clean off any debris caused by the drilling operation to keep the floor level. Restore the assembled Base Channel to its planned position.

8. Using a spirit level, check the horizontality of the Base Channels at all the positions. Adjust or clean the floor if the spirit level is not horizontal, then set the assembled Base Channel and check the horizontality again.

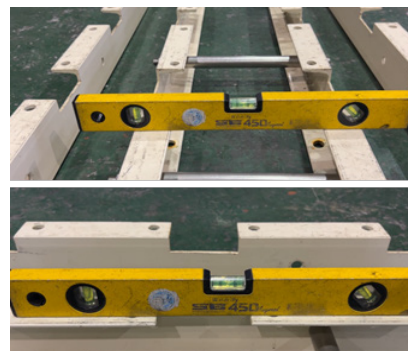

9. Secure the Base Channel on the floor with the Anchor Bolts [6]. Check the level of the Base Channel after the Anchor Bolts are installed and ensure there is no gap between the Base Channel and the floor. If there is a gap between the Base Channel and the floor, use shims or stiffeners to fill the gap.

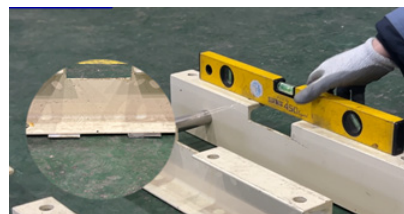

In case of using Chemical Anchor, leave enough time for the Chemical to harden before working with it. It is recommended that the Chemical Anchor work be done the day before module installation.

10. Take UF modules and partition frames out from the UF package box. Place the partition frame on the floor and put the UF module [7-10] on it.

Two or more workers are required.



11. Set a bucket to receive the preservative solution and remove a plugging plate of the upper side nozzle. Be cautious of preservative solution which comes out when the plate is opened. Turn the module nozzle down and remove the preservative solution.

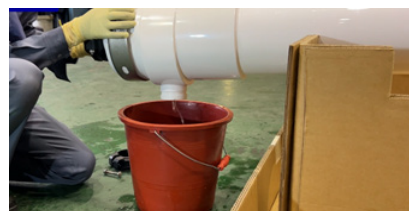

Remove the top cap and bottom cap. Keep the removed V-band for Module, O-ring [8, 9], and Housing Joint 65A [10] as they will be used again when assembling a rack. The removed caps are not required to assemble racks.



WARNING

- Wear rubber gloves and safety glasses when draining the preservative solution, sodium hypochlorite solution (200 mg/L as Cl₂). If this solution splashes onto the skin, wash the affected part with running water. If the solution gets in eyes or mouth, wash the affected part with enough amounts of running water for over 15 minutes and see the doctor immediately.



CAUTION

- The preservative solution should be drained out before using the modules. Do not allow the modules to dry even for a few hours. If the rack assembly process does not finish within the time, fill tap water or equivalent quality water into assembly rack and UF modules from feed water side such as upper side nozzle of UF module, and seal all openings (at least all air injection points and side openings of Header-1#2s) to prevent the hollow fiber membrane from drying out. Store the rack filled with water according to the storage method described in the later section.

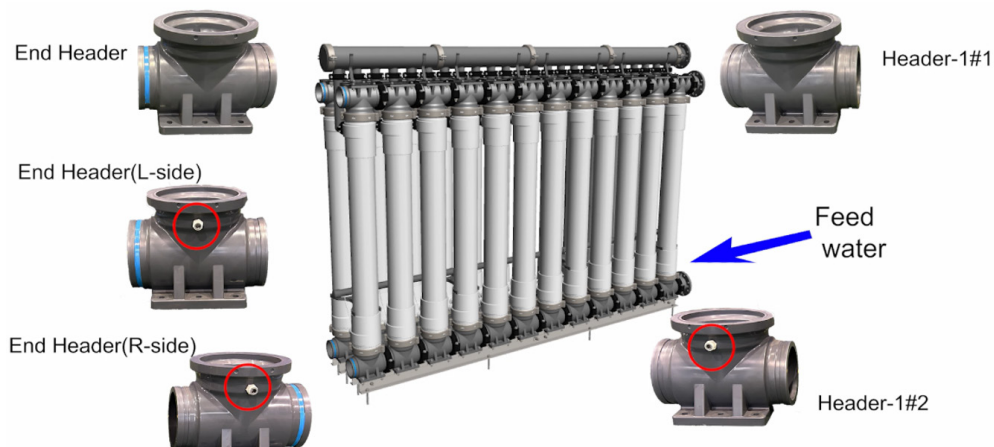

12. Place Header-1#1 [11] and Header-1#2 [12] to each end of the module. Air injection is attached to the Header-1#2, but not to the top header. Make sure that the O-ring [9] between the module and the header fits correctly.

Adjust the header direction so that the module edge protrusion and the header circle mark a,b) are aligned.

a) Header-1#1 (Top Header): use the right circle mark.

b) Header-1#2 (Bottom Header): use the left circle mark.

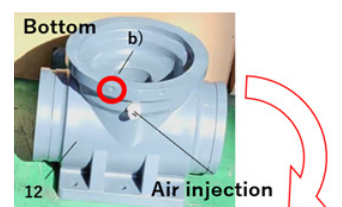
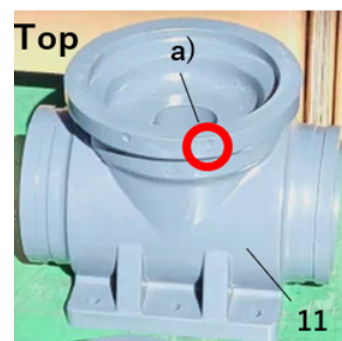



13. Cover with a pair of the V-band half-shells for Module [8] which is described in step 11 so that the protrusion and the circle mark are visible through the V-band window and tighten the V-band. Make sure the bolts are securely fastened to prevent leaks. When tightening the V-band, the bolt sets must be fastened until the gap between the ends of each V-band half-shell reaches below 2 mm.



14. If the V-band gap does not reach 2 mm or less, remove the V-band and check for failure.

Repeat the steps 10 to 14 for all modules for the Rack. This work can be done in advance as these steps might be bottlenecked during assembly.

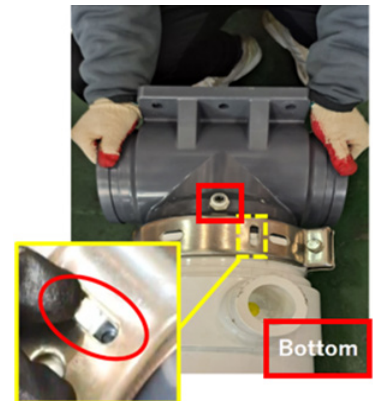



CAUTION

- Be sure to tighten each header with header bolts. The loose header bolts may cause serious damage to the header.
- Be careful not to attach each header to the module upside down. Locate an Air Out nozzle the upside of the UF module. Confirm the module is installed in the right direction.

15. To connect to the pipes, attach Flange Conversions to the four headers (the top and bottom headers) of two modules of the rack.

Using the Housing Joint DN150 with gasket [15], attach a Flange Conversion [16] to each header of one module (Module #1).



One worker holds the Flange Conversion while the other worker tightens the Housing Joint DN150.

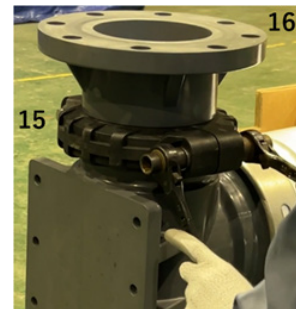

16. Repeat the step 15 for another module. (Module #2)

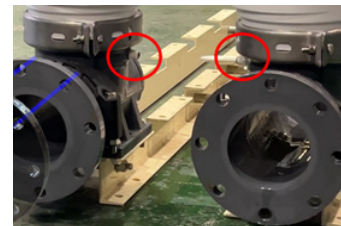

*Note that the header opening attached to the Flange Conversion is symmetrical with Module #1.



17. Put Module #1 vertically on the Base Channel with its side nozzle facing the inside of the rack.

Be cautious of preservative solution which comes



 DANGER	<ul style="list-style-type: none"> ● Use equipment such as chain blocks, a crane, or a forklift truck when handling the module. The HFUG-2020HN module is too heavy to handle by hand. ● Do not drop or fall down the module and the parts.
 CAUTION	<ul style="list-style-type: none"> ● Attach a gasket when assembling Housing Joint DN150. ● Be careful not to install the module upside down. Confirm the module is installed in the right direction. ● Do not allow the hollow fiber membranes to dry even for a few hours, especially in summer. ● Do not freeze the module.

18. Position Module #1 so that three edges of the Header-1#2 (Bottom Header) are aligned with those of the Base Channel (See the yellow line in the right figure).

Place a spirit level tool along the module and make sure the module is installed in vertical direction (see the step 21).



 CAUTION	<ul style="list-style-type: none"> ● If the module is not installed vertically, the effect of the air scrubbing would be decreased, and an effective filtration will be impaired.
--	--

19. Place the four holes in the Header-1#2 over the holes in the Base Channel and fix the Header-1#2 (Bottom Header) with the M12 X 55 mm bolt set [17].

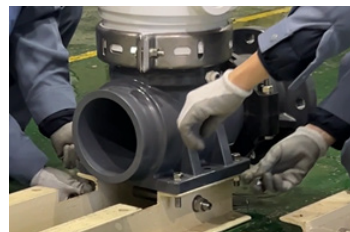

**WARNING**

- When tightening or loosening the Hexagon Bolts and the Hexagon Nuts into or from Header-1#2 (Bottom Header) and Base Channel, keep holding the module in position to prevent tipping and be careful not to be injured by hitting the body or clipping fingers.

20. Using the Housing Joint 65A [10] described in the step 11, attach the Long Elbow [18] to the upper side nozzle of the module so that the long pipe of the Long Elbow points vertically upwards.



21. Place a spirit level tool along the long pipe of the Long Elbow and make sure the Long Elbow is installed in vertical direction at least at two sides.

**CAUTION**

- If the Long Elbow is not installed vertically, it would cause assembly failure and result in leakage.

22. Insert the Air Tube [19] to the Header-1#2 (Bottom Header) of Module #1.



23. Attach the gaskets for the top and bottom headers in the Housing Joints DN150 [15] to the opening of each header of Module #1.

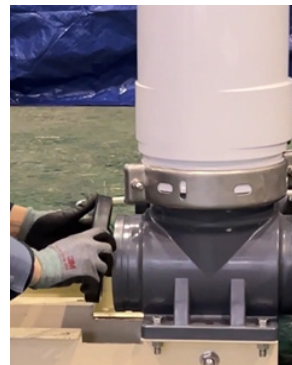

24. Repeat the steps 17 to 23 to install Module #2 on the Base Channel opposite to Module #1 with its side nozzles facing Module #1 and attach the Long Elbow.

At least three workers are required for this step.

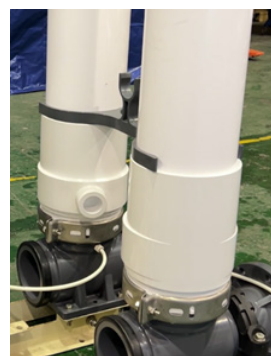

25. Move and prepare another module (Module #3) assembled in the step 14 near the rack, put the module vertically on the Base Channel as the step 17. Repeat the steps 18 to 23.



26. Connect the Headers of Modules #1 and #3 with the Housing Joint DN150 [15] which corresponds to the gasket described in the step 23.



27. Repeat the steps 17 to 26 continuously to install the module next to the installed module that starts from Module #2, to attach the Long Elbow, and to connect the adjacent Headers.

On the way to these steps, install Central Fixtures [20].



28. Install Central Fixture [20] so that it holds the two module housings described below (24-module rack for instance).

- Modules #1 and #2
- Modules #7 and #8
- Modules #15 and #16
- Modules #23 and #24

Push the Central Fixture down to the position where module housing doesn't move.

If the rack is not a 24-module rack, please contact us regarding the positions of the Central Fixtures.



29. Repeat the steps 11 to 28 for the remaining modules of the rack except for two modules to which End Headers [13,14] will be attached.

Regarding the two modules, attach top End Header [13] and bottom End Header [14]. (Module #E1, Module #E2)

*Note that there are two types of bottom End Headers, R-side and L-side, and attach them to each module.

Bottom end header (R-side)



Bottom end header (L-side)

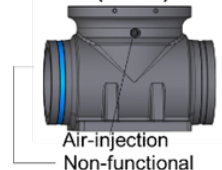

30. The mounting positions of the Flat Bars [21], the Bolts [22], and the Manifold Base [23] are shown in the drawing below. The Flat Bars and the Manifold Base should be fixed in the following order:

- 1) Placing and fastening the Flat Bars at the outer sides (1-1, 1-2, 4-1 and 4-2). Both ends of the Flat Bar are fastened with bolts.
- 2) Placing the Flat Bars at the inner sides and the Manifold Base. The Manifold Base is positioned to support both ends of the Manifold.
- 3) Fastening the Flat Bar at the inner sides and the Manifold Base

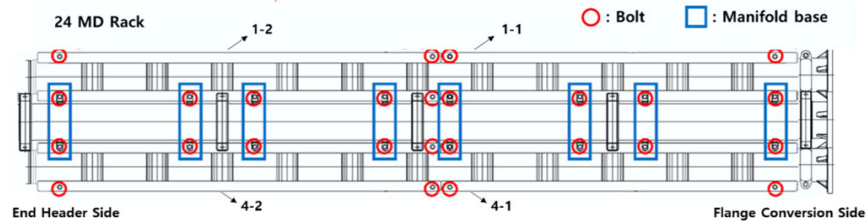

If the rack is not a 24-module rack, please contact us regarding the positions of the Manifold Bases.

* To install the Flat Bars, it is required to access from both sides of the rack. Place Flat Bars 1-1, 1-2, 4-1 and 4-2 [21] on the outside of the Header-1#1 (Top Header) and fix them with the M12 X 55 mm Bolt Sets [22].

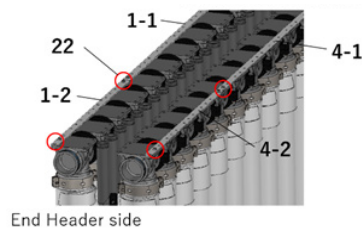

31. Place Flat Bars 2-1, 2-2, 3-1, and 3-2 [21] on the inside row of the Header-1#1 (Top Header) and place the Manifold Base [23] on the Flat Bar. If the Flat Bar length is different, place the shorter Bar on the Flange Conversion side. The length of the inner row Flat Bar will be the same as the length of the outer row Flat Bar. Assemble the Flat Bars and Manifold Bases to Header-1#1 [11] with the M12 X 55 mm Bolt Sets [22]. Screw the bolts through the holes of Manifold Base, Flat Bar, and the Header-1#1 (Top Header) [11]. Tighten the bolt at the end of the Flat Bar first (along with the Manifold Base) and tighten the remaining bolts.

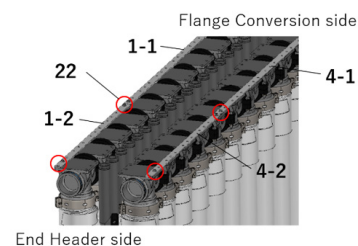

**WARNING**

- Make sure all bolts are tightened, otherwise the Header-1#1 (Top Header) will get damaged during operation of the UF system.

32. Assemble the manifold for the Flange Conversion side. Wet the O-ring with clean water. Using the O-rings [24] and the V-bands for Manifold [25], attach the Flange Conversion [26] to the Manifold [27]. Make sure the bolts are securely fastened to prevent leaks. Tighten the V-bands until the gap between the ends of the V-bands is 2 mm. Use a 2 mm shim plate to check the gap. If the V-band gap does not reach 2 mm or less, remove the V-band and check for failure.

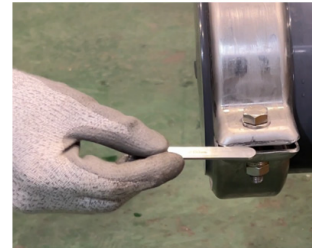
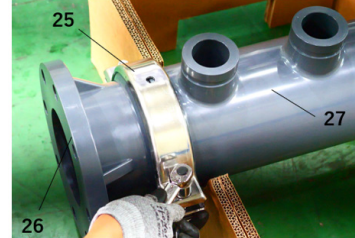

33. Assemble the manifold for the End Header side. Wet the O-ring with clean water. Using the O-ring [24] and the V-bands for Manifold [25], attach the Manifold Stopper [28] to the Manifold [27]. Make sure the bolts are securely fastened to prevent leaks. Tighten the V-bands until the gap between the ends of the V-bands is 2 mm. Use a 2 mm shim plate to check the gap. If the V-band gap does not reach 2 mm or less, remove the V-band and check for failure.

*Cover the last end Manifold with the Manifold Stopper.



34. Place the Manifold with the Flange Conversion described in the step 29 on the Manifold Base. Insert the gaskets for Housing Joints 65A [29] to each Manifold hole so that the edge of each Manifold piping is visible.

The gaskets for Housing Joints 65A [29] can be inserted at this step or at the step 32 or 33.

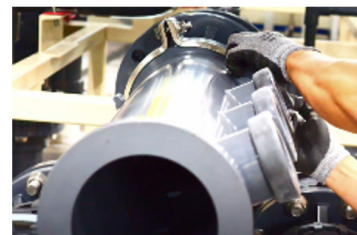

35. Reposition the Manifold so that the Long Elbow and Manifold pipe are in close proximity. In all piping, ensure that the distance between the center line of the Manifold pipe and the center line of the Long Elbow pipe is less than 6 mm. Then, shift the gasket to cover the Long Elbow and the Manifold.

If this distance is over 6 mm, check the following steps and positions.

- 1) Level of the Base Channel (refer to the step 8).
- 2) Alignment of the header marks with the module protrusion (refer to the step 14).
- 3) Alignment of the edge of the headers with the edge of the Base Channel (refer to the step 18).
- 4) Vertical mounting of the Long Elbow (refer to the step 20 and 21).

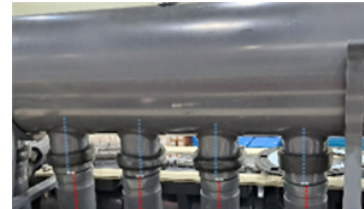
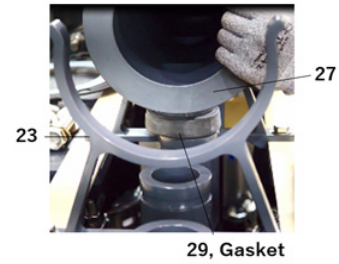

36. Connect the Long Elbow and the Manifold with the Housing Joint 65A [29].



37. Place another Manifold on the adjacent Manifold Base and connect as in the steps 34 to 36. Wet the O-ring with water. Connect the adjacent Manifolds with the O-ring [24] and the V-band for Manifold [25]. Make sure the bolts are securely fastened to prevent leaks.

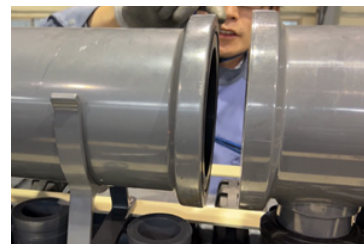

38. Repeat the steps 34 to 37 continuously to install the Manifolds.

39. Repeat the steps 34 to 37 for the last Manifold with the Manifold Stopper described in the step 33.

40. Connect the Air Pipe-1 and Air Pipe-2 [30] with 50A gasket and M16 X 65 mm Bolt Sets [31].

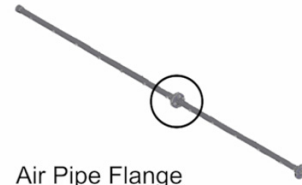

Air Pipe Flange
50A Gasket
&
M16 x 65mm Bolt Sets

41. Place the Air Pipe assembled above on the Central Fixture [20].



42. Insert the Air Tube [19] of each module to the Air Pipe one by one.

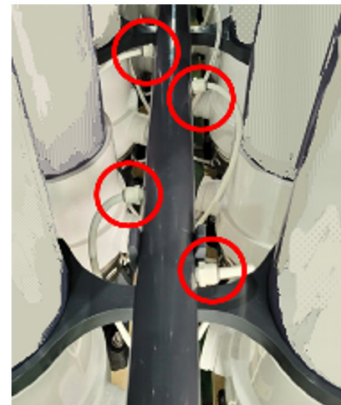



WARNING

- Make sure that the air pipes are properly fixed. If not fixed properly, the Air Tube and/or the Air Pipe may be blown off or run wild during air scrubbing.

43. Connect the Flange Conversions of all headers and Manifold, and the Air Pipes to the existing pipes.



A check valve should be prepared and installed between the Air Pipe of the rack and the existing pipes to avoid water reverse flow. The check valve is not included in the parts supplied by Toray.

 CAUTION	<ul style="list-style-type: none"> ● Do not allow the hollow fiber membranes to dry out by exposing in the open air even for a few hours, especially in summer season. Fill tap water or equivalent quality water into UF modules from feed water side and close all openings such as flange end in order to prevent the hollow fiber membrane from drying out in case a customer prepares connecting pipework after setting up Toray products.
 WARNING	<ul style="list-style-type: none"> ● Make sure that the connection is established tension-free any time. ● Make sure that pipes are properly fixed and correctly positioned so that center lines of each pipe are aligned. ● Place the Base Channel on a level and stable ground. Make sure that stable connection is established in the correct position. Use the flexible joints prepared by the contractor as needed depending on the connection distance to the piping.

2. Disassembly and Disposal

Before disassembly, the corresponding rack must be isolated after the water is all drained out.

The disassembly procedure is performed in reverse order to the assembly. Two workers or more should be required for disassembly.

 DANGER	<ul style="list-style-type: none"> ● When disassembling “Toray UF TUF Rack”, set up a scaffold in advance. Never climb the rack. Use protective equipment to ensure the safety. ● Use equipment such as chain blocks, a crane, or a forklift truck when handling the module. The module is too heavy to handle by hand. ● Do not drop the module and the parts.
 WARNING	<ul style="list-style-type: none"> ● When tightening or loosening the rack, secure a sufficient area before working, and be careful not to pinch fingers. ● When tightening or loosening the Hexagon Bolts and Nuts into or from Header-1#2 (Bottom Header) and Base Channel, keep holding the module in position to prevent tipping and be careful not to be injured by hitting the body or clipping fingers.



CAUTION

- Do not allow the hollow fiber membranes to dry even for a few hours, especially in summer. Do not allow the module to dry even for a few hours. If the rack disassembly process does not finish within the time, fill tap water or equivalent quality water into assembly rack and UF modules from feed water side such as upper side nozzle of UF module, and seal all openings (at least all air injections and side openings of Header-1#2s) to prevent the hollow fiber membrane from drying out. Store the rack filled with water according to the storage method described in the later section.
- Do not freeze the module.

VI. Operation

1. Filtration

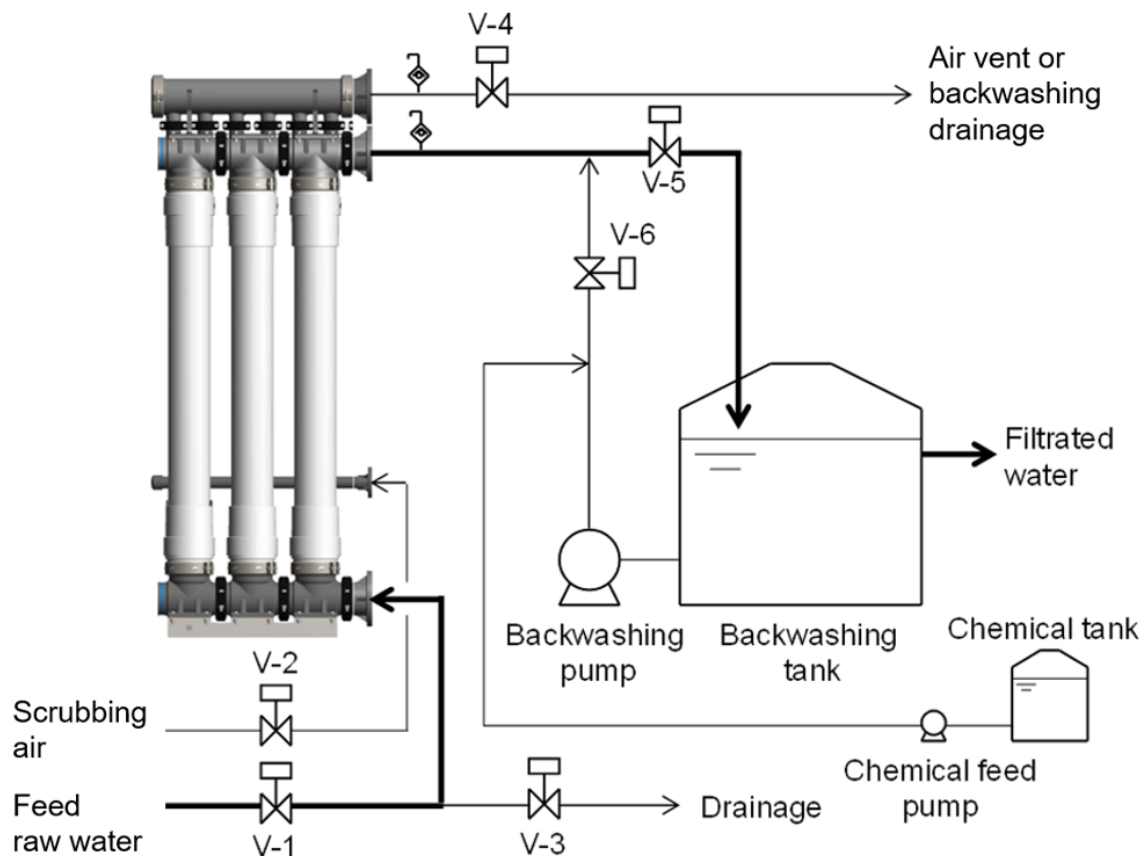



Fig. 3. Standard Example of Membrane Pipe Connection

- (1) Check that all pipes are connected appropriately and flushed out prior to the operation. Fig. 3 shows a standard example of membrane pipe connection.
- (2) Make sure the feed water valve (V-1), the drainage valve (V-3), and the air-scrubbing valve (V-2) are “closed”.
- (3) Make sure the filtrate water valve (V-5) is opened. Open the air vent valve (V-4).
- (4) Gradually open the feed water valve (V-1) and fill the feed water to the module to purge any air out.

 DANGER	<ul style="list-style-type: none"> ● Do not open the feed water valve (V-1) quickly, or water-hammer may occur, and the module could be damaged. Be sure to take around 5 seconds to open the backwashing valve.
---	---

- (5) Confirm that the air is out of the module, and then close the air vent valve (V-4).
- (6) Set appropriate volume of filtrate water flow.

 DANGER	<ul style="list-style-type: none"> ● Do not exceed 600 kPa (87.0 psi) to avoid damage to the module. ● Operating conditions including the filtration flux and the physical cleaning should be properly set up to observe the rise of trans-membrane pressure (Details are described in the next section). Please contact us for any technical support if necessary.
--	---

- (7) When stopping the operation, gradually close the feed water valve (V-1).

2. Backwash and Air-scrubbing

The physical cleaning with backwash followed by air-scrubbing should be carried out periodically and automatically for the continuous filtration. The frequency of the physical cleaning mainly depends on the raw water quality. For instance, a typical frequency for surface water filtration is once every 30 minutes, but this might be changed depending on raw water quality. Please contact us if you need technical support. Fig. 4 and Fig. 5. show the standard flow diagrams for backwash and air-scrubbing.

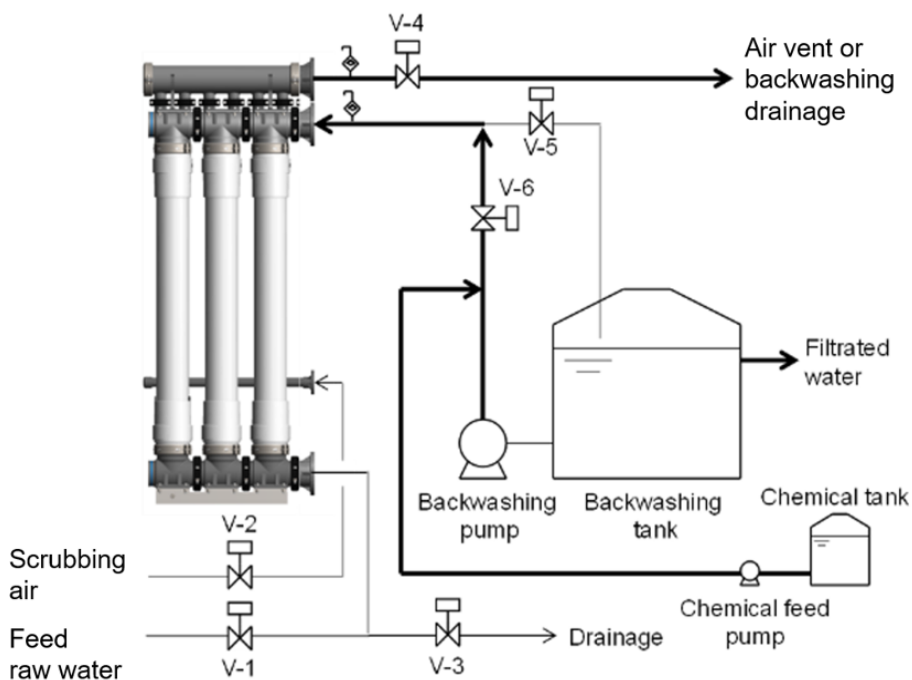

Fig. 4. Flow Diagram for Backwash

- (1) Close the feed water valve (V-1) and stop the feed water pump.
- (2) Open the air vent valve (V-4).
- (3) Close the filtrate water valve (V-5) and open the backwashing valve (V-6) to feed back the filtrate water from the backwashing tank to the membrane module. During backwash, the chemical feed pump can be operated to dose chemical to the backwash water. The chemical is usually sodium hypochlorite, and the dosing rate should be up to 50 mg/L as Cl₂.

The flow rate of backwash water is set up in advance for 1.0 to 1.5 times the filtrate flow rate. Do not exceed Max. Backwash Flow described in Table 4.

**DANGER**

- Do not open the backwashing valve (V-6) quickly, or water-hammer may occur, and the module and/or rack parts could be damaged. Be sure to take around 5 seconds to open the backwashing valve.

- (4) After backwashing for a specified period (normally 30 seconds, up to 60 seconds), close the backwashing valve (V-6) and stop the backwashing pump.
- (5) Open the air vent valve (V-4) and the air-scrubbing valve (V-2) for a specified time (normally 30 seconds, up to 60 seconds).

**CAUTION**

- The air flow rate for air-scrubbing should be within the range below. Excessive air flow rate may damage the hollow fiber membrane.

HFUG-2020HN: 4.8 – 9.0 Nm³/h, normally 6.0 Nm³/h
(2.8 – 5.3 scfm, normally 3.5 scfm)

The maximum required air pressure during the air-scrubbing for the rack will be 40 kPa (6 psi).

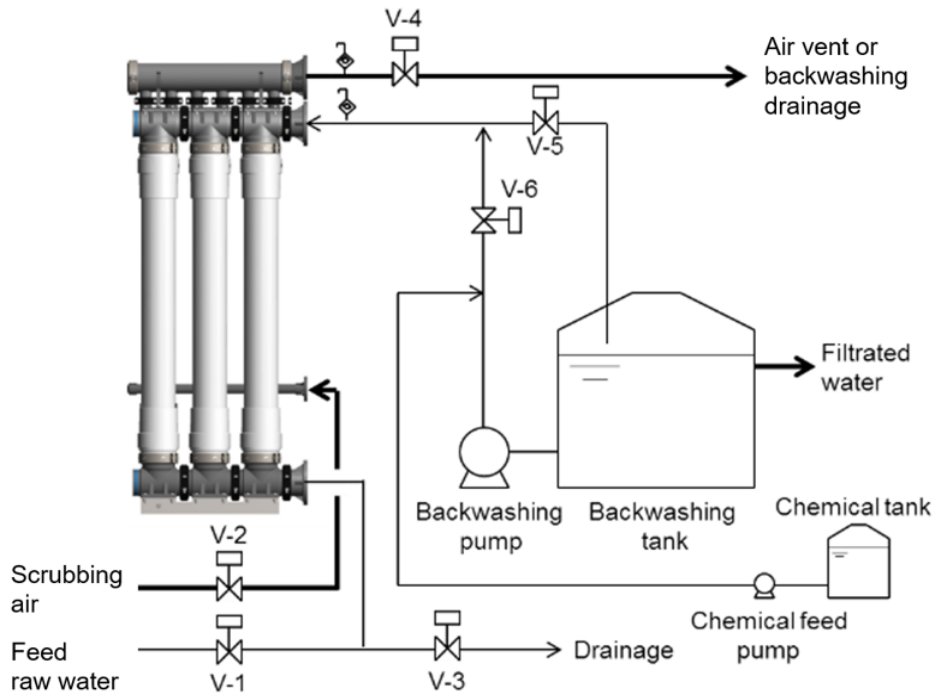

Fig. 5. Flow Diagram for Air-scrubbing

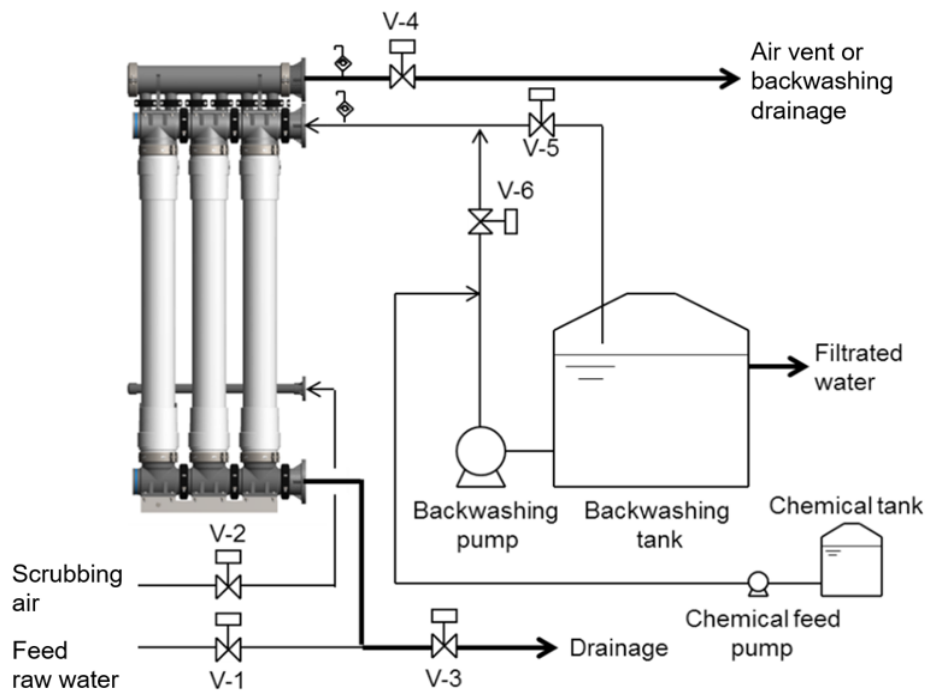



Fig. 6. Flow Diagram for Drainage

- (6) Close the air-scrubbing valve (V-2) and open the drainage valve (V-3).
- (7) Close the drainage valve (V-3) after the water is all drained out.
- (8) Run the feed water pump and open the feed water valve (V-1).
- (9) Close the air vent valve (V-4) after the air is purged from the module.

 CAUTION	<ul style="list-style-type: none"> ● Constantly monitor the filtrate water quality during filtration and stop the operation if abnormal water quality is detected. If abnormal water quality is detected, check the integrity of the element with filtrate turbidity and so on. The test procedure is provided as the technical information by Toray.
--	--

3. Toray Maintenance Cleaning

Instead of chemical dosing for every backwash, soaking the membrane in chemical solution several tens of minutes a day is also effective for membrane performance retention. This process is called Toray Maintenance Cleaning (TMC). The TMC is usually held following the backwash and air-scrubbing which does not contain the chemical dosing. The frequency

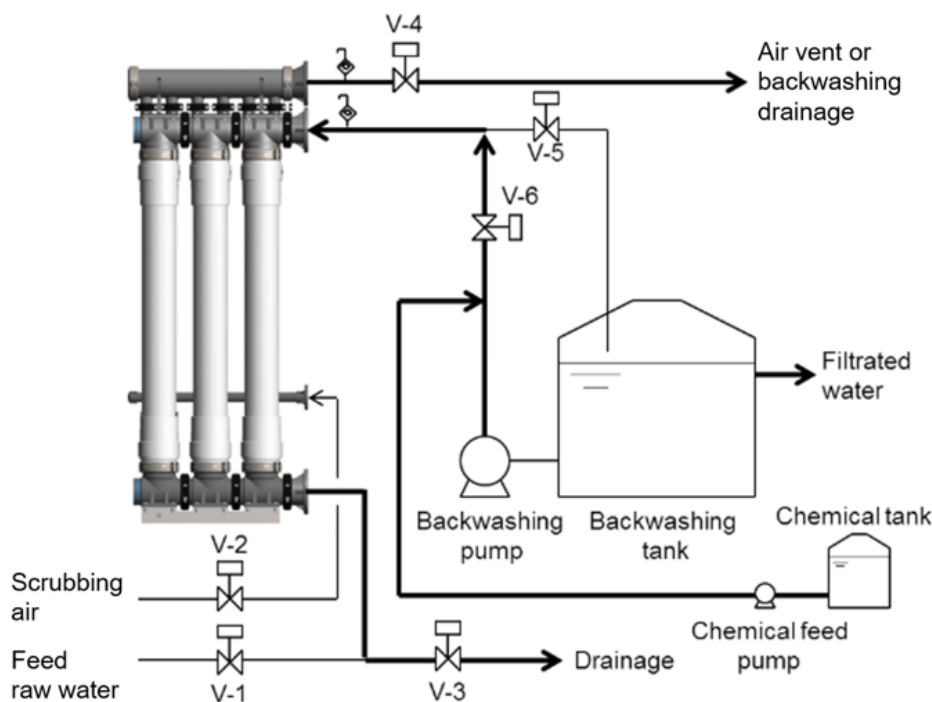



Fig.7. Flow Diagram for TMC – Pre-backwashing

- (1) Open the air vent valve (V-4) and the drainage valve (V-3).
- (2) Open the backwashing valve (V-6), run the NaClO feed pump and the backwashing pump to feed the chemical enhanced backwash water to the membrane module. The chemical is usually sodium hypochlorite, and the dosing rate should be up to 300 mg/L as Cl₂ for TMC.
The flow rate of backwash water is set up in advance for 1.0 to 1.5 times the filtrate flow rate. Do not exceed Max. Backwash Flow described in Table 4.

 DANGER	<ul style="list-style-type: none"> Do not open the backwashing valve (V-6) quickly, or water-hammer may occur, and the module and/or rack parts could be damaged. Be sure to take around 5 seconds to open the backwashing valve.
---	--

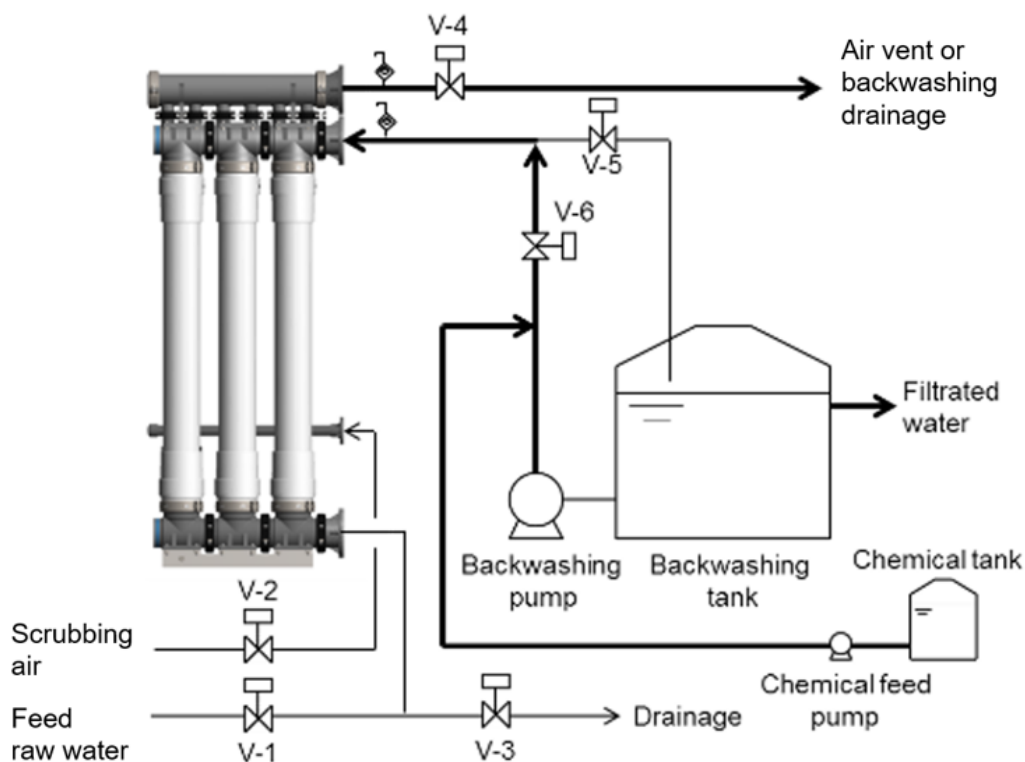



Fig. 8. Flow Diagram for TMC – Chemical Backwashing

- (3) As soon as the NaClO is detected in the drainage water, close the drainage valve (V-3). NaClO diluted with UF filtered water is applied to TMC cleaning solution usually. In this case, if the filtered water contains a lot of organic matter, NaClO will be consumed by the organic matter, which may result in a substantial decrease of cleaning efficiency. Please contact us if there is such concern.
- (4) After making sure water comes out from upper part of the side nozzle of the membrane module, stop the NaClO feed pump, close the backwashing valve (V-6), and stop the backwashing pump.
- (5) Soak the membrane in the chemical for a specified time (normally 20 minutes). And then, open the air-scrubbing valve (V-2) for a specified time (normally 60 seconds).

 CAUTION	<ul style="list-style-type: none"> The air flow rate for air-scrubbing should be within the range below. Excessive air flow rate may damage the hollow fiber membrane. <p style="text-align: center;">HFUG-2020HN: 4.8 – 9.0 Nm³/h, normally 6.0 Nm³/h (2.8 – 5.3 Scfm, normally 3.5 Scfm)</p> <p>The maximum required air pressure during the air-scrubbing for the inside of the rack will be 40 kPa (6 psi).</p>
--	--

- (6) Close the air-scrubbing valve (V-2), open the drainage valve (V-3) to drain the chemical from the membrane module.
- (7) Close the drainage valve (V-3), and then open the backwashing valve (V-6) and run the backwashing pump (normally 30 seconds). Stop the backwashing pump and close the backwashing valve (V-6), and then open the air-scrubbing valve (V-2) (normally 30 seconds).
- (8) Repeat the process of (6) to (7) until the overflow water meets the required water quality.
- (9) Make sure the air-scrubbing valve (V-2) and the backwashing valve (V-6) are “closed” and the backwashing pump is “stopped”.

 CAUTION	<ul style="list-style-type: none"> ● Constantly monitor filtrate water quality during filtration and stop the operation if abnormal water quality is detected. In that case, check the integrity of the element with PDT (Pressure Decay Test) or DAF (Diffusive Air Flow) Test. The test procedure is provided as the technical information by Toray.
--	---

4. Basic Trans-Membrane Pressure Calculation

To calculate accurate Trans-Membrane Pressure (TMP), it is necessary to involve the height difference of inlet and outlet pressure gauges (see Fig. 9).

Example calculation of TMP (The specific gravity of water is set to 1)

$$\begin{aligned}
 \text{TMP} &= (P_{\text{in}} - H_{\text{in}}) - (P_{\text{out}} - H_{\text{out}}) \\
 &= (70 - 10) - (20 - (-25)) \\
 &= 60 - 45 \\
 &= 15 \text{ kPa}
 \end{aligned}$$

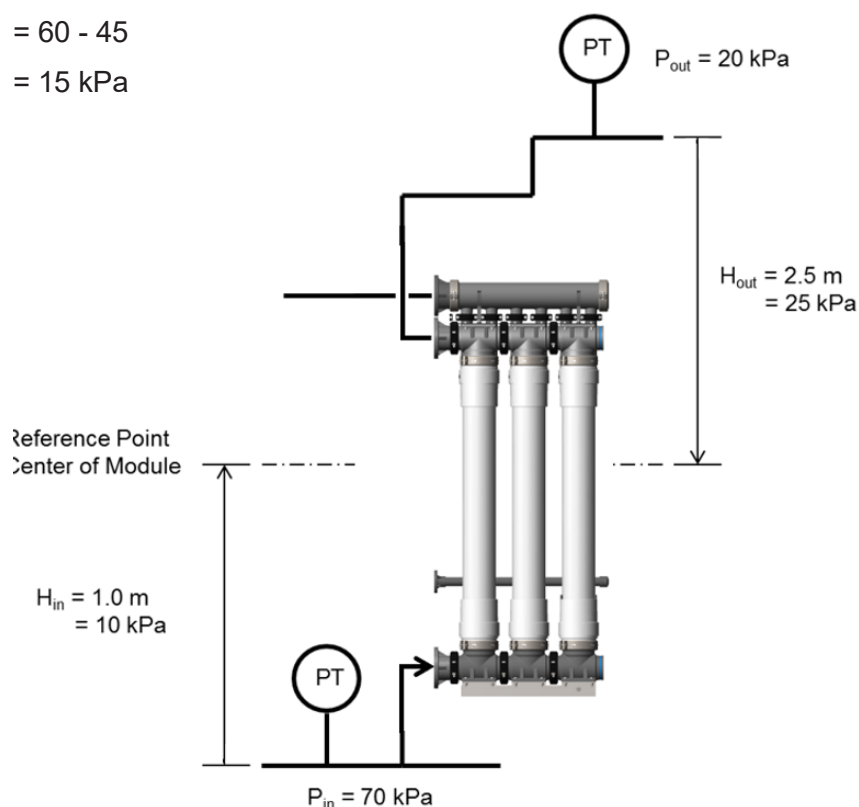

Fig. 9. Basic TMP Calculation

Note, the following formula may also be used:

$$\begin{aligned} \text{TMP} &= P_{\text{in}} - P_{\text{out}} - \text{total } \Delta H \\ &= 70 - 20 - (10 - (-25)) = 15 \text{ kPa} \end{aligned}$$

5. Temperature Correction Factor

The permeability of the membrane is influenced by temperature mainly because the water viscosity changes with temperature. It is necessary to eliminate the temperature effect with the Temperature Correction Factor (TCF) shown in Fig. 10 to evaluate the permeability correctly.

A Trans-Membrane Pressure (TMP) measured at some real temperature can be converted to 25 deg C corrected TMP with multiplying by TCF at real temperature.

A filtrate flow rate measured at some real temperature can be converted to 25 deg C corrected filtrate flow rate with divided by TCF at real temperature.

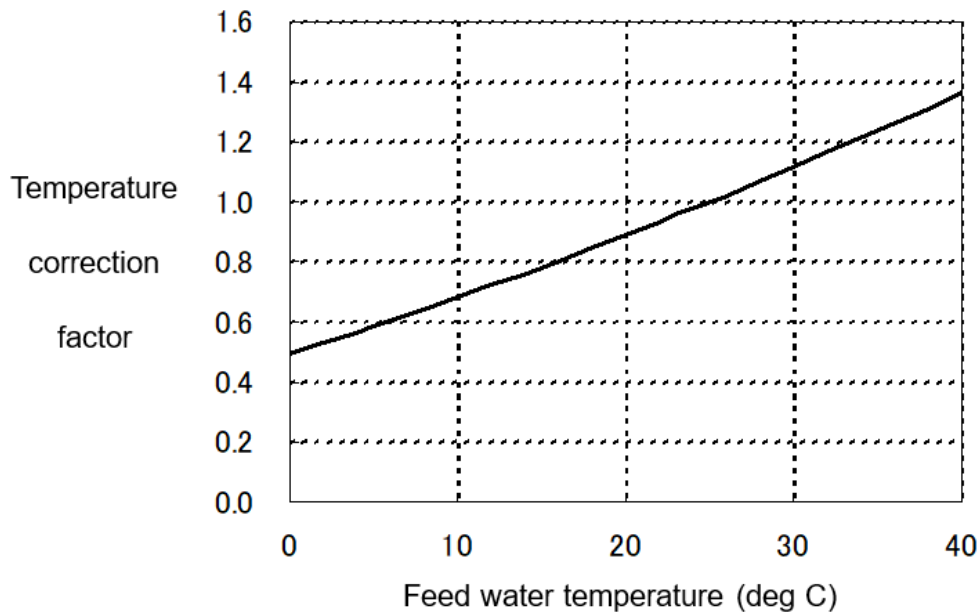

Fig. 10. Temperature Correction Factor (TCF)

The equation for calculating TCF at a temperature (T deg C) is as follows.



$$\text{TCF} = 0.0008902 / (0.01257187 \times \text{EXP}((10.005806436 \times (273.15 + T))) / (0.001130911 \times (273.15 + T) - 0.000005723952 \times (273.15 + T) \times (273.15 + T))) / 1000)$$

6. Performance Recording

To effectively evaluate the current UF system performance, including quick recognition of undesirable trends in operation and appropriate countermeasures, it is necessary to compare current operating performance data with a performance data which were recorded at the first placed in service. Log the data which is related about the UF operation and must include regular information on: flow, trans-membrane pressure, contractually specified feed water quality parameters and temperature, and elapsed time since start-up (days). The data might be captured and logged automatically every 2 seconds to support optimizing the UF operation system.

VII. Chemical Cleaning

The chemical cleaning should be carried out to remove foulants accumulated in the membrane pores or sticking to the membrane surface.

 DANGER	<ul style="list-style-type: none"> ● Pay full attention when handling chemicals and be sure to wear the safety gear such as glasses and gloves. The chemicals used for the chemical cleaning are harmful to people. If chemicals directly contact skin, eyes, or other body parts, take the appropriate treatment as stated in its SDS. ● Do not mix sodium hypochlorite with acid. Such mixture generates toxic chlorine gas. ● Stop operations when any instrumental anomalies occur, or any sign of anomalies are observed.
 WARNING	<ul style="list-style-type: none"> ● Carry out the chemical cleaning before the trans-membrane pressure rises to 200 kPa (29.0 psi), or the module filtration performance could be degraded significantly. ● Follow the instruction described in this manual when carrying out the chemical cleaning. If using the unacceptable chemicals or perform the cleaning altered from the recommended procedure, the membrane could be seriously damaged.

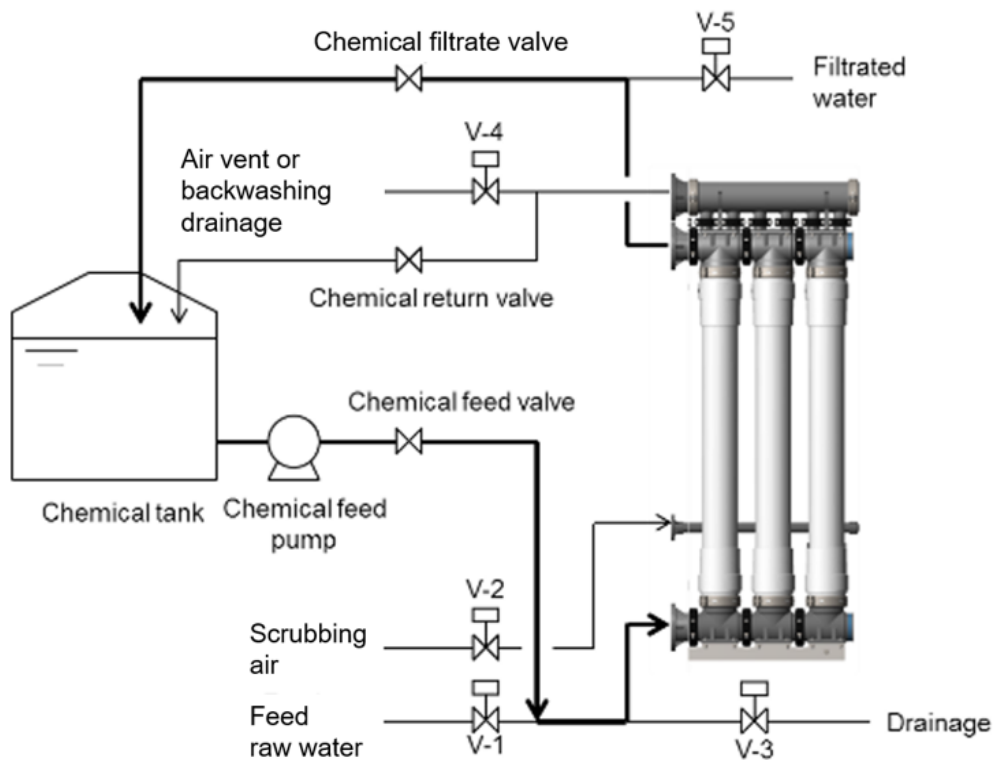

Fig. 11. Flow Diagram for Chemical Cleaning for Filtrate Side

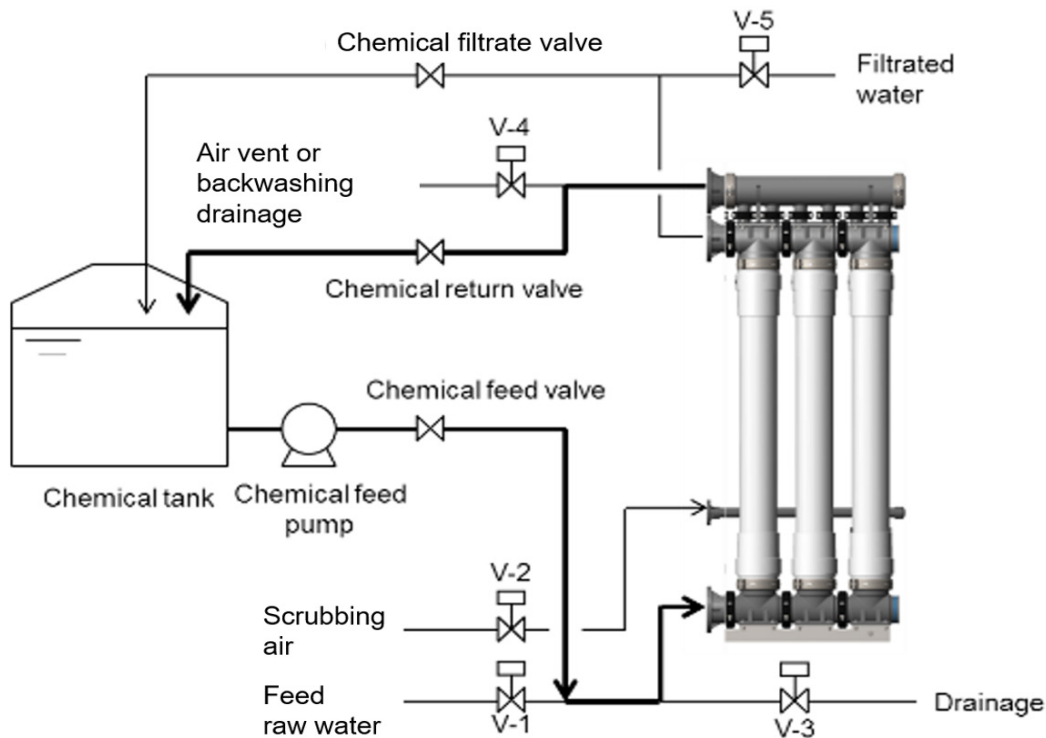

Fig. 12. Flow Diagram for Chemical Cleaning for Feed Side

- (1) The flow diagrams for cleaning simultaneously both outer surface and inside of hollow fiber membranes is shown in Fig. 11 and Fig. 12. The flow diagrams can be changed case by case. Please contact us for further information if necessary.
- (2) Open the chemical return valve and then open the chemical feed valve.
- (3) Run the chemical feed pump to start for chemical circulation. Then, open the chemical filtrate valve to let the chemical pass through the membrane.
- (4) Circulate the chemical for a specified time.
- (5) Stop the chemical feed pump.
- (6) Drain the chemical and rinse the cleaning line and the module thoroughly with product water.



DANGER

- Take appropriate measures to prevent the misoperation or accidents that could cause the chemicals to get into the product water. Check the piping and ensure that each valve is correctly positioned before starting the chemical cleaning.



- (7) The standard conditions for chemical cleaning are shown in Table 9.
 - The concentration and each circulation time shown in Table should be observed. Otherwise, the membrane module may get damaged and/or the life of membrane may be shortened.
 - The cleaning temperature should be 20 to 40 deg C.
 - The circulation flow rate for each type of the module is as follows.
 - HFUG-2020HN: 62.5 L/min (16.5 gpm)

Table 9. Standard Conditions for Chemical Cleaning

Pollutants	Chemicals	Maximum Concentration	Circulation Time (hr)
Inorganic substances	Citric acid *1)	3.0 wt.%	1 - 3
Organic substances	Sodium hypochlorite	3,000 mg/L as Cl ₂ (10 ≤ pH ≤ 12)	1 - 3

*1): Besides citric acid, the following acids are acceptable.

- Hydrochloric acid (with the maximum concentration of 1.0 mol/L)
- Oxalic acid (with the maximum concentration of 1.0 wt%)
- Sulfuric acid (with the maximum concentration of 0.05 mol/L)
- Nitric acid (with the maximum concentration of 0.1 mol/L)

 DANGER	<ul style="list-style-type: none"> ● Do not mix sodium hypochlorite with acid. Such mixture generates toxic chlorine gas. ● Do not use any other chemicals than those indicated above.
 CAUTION	<ul style="list-style-type: none"> ● In the case of cleaning with acid and with sodium hypochlorite alternately, rinse the cleaning line and the module with clean water thoroughly after each cleaning. Use product water for rinsing and make sure that pH of the water in the module is in the range between pH 6.5 and 7.5 after rinsing.



Instruction

The chemical cleaning should be done at least once a year. Otherwise, the module filtration performance could be degraded.

VIII. Storage of Membrane Module

Follow the instruction below when you store the modules.

 CAUTION	<ul style="list-style-type: none"> ● Be careful not to freeze the modules.
--	---

1. Storage of New Membrane Modules

Keep the modules in the original package box in a dark and cool place (1 to 40 deg C). Avoid direct sunlight and moisture.

2. Storage of Membrane Modules and Racks after Use

(1) Short-term/temporary shutdown or storage

In the case of the suspension of operation for less than four days, stop the feed water and keep modules full of water at 1 to 40 deg C.

If suspended from four days to seven days, fill the module with the chemical described in Table 10. Use filtrate quality water. Keep the modules at 1 to 40 deg C.

Table 10. Conditions for Storing Membrane Modules for Seven Days

Maximum Storage Period	Preservative Solution	Concentration of the Chemical
7 days	Sodium hypochlorite	20 mg/L as Cl ₂

(2) Long-term storage

First, carry out a chemical cleaning with sodium hypochlorite. Fill the module with the chemical described in Table 11. Use filtrate quality water. Follow the instructions shown in Table 11.

Keep the modules sealed with the aqueous chemical solution shown in Table 10 or Table 11. If removing modules from the system, seal the module and store out of direct sunlight. Keep the modules at 1 to 40 deg C.

Table 11. Conditions for Storing Membrane Modules for More than Seven Days

Storage Period	Preservative Solution *1)	Concentration of the Chemical
More than 7 days	Sodium hypochlorite	10 mg/L as Cl ₂ *2)
	Sodium bisulfite	1,000 mg/L

*1): Select either sodium hypochlorite or sodium bisulfite chemical solution.

*2): Be careful not to exceed the sodium hypochlorite contact upper limit shown in Table 3.



DANGER

- Rinse the module thoroughly with clean water after the chemical cleaning with sodium hypochlorite and fill the module with sodium bisulfite solution. Toxic chlorine gas is generated when sodium hypochlorite is mixed with sodium bisulfite without flushing with water first.

3. Replace Preservative Solution

Check the pH value of sodium bisulfite solution as the preservative and replace the chemical if the pH is below three (3.0). Sodium bisulfite solution with a pH of 3 to 6 is active for the preservation. Sodium bisulfite reacts with oxygen and forms sulfuric acid which results in a lower pH. In case that sodium hypochlorite is being used as the preservative, replace it if the sodium hypochlorite concentration is less than 0.1 mg/L as Cl₂.

IX. Appendix

Following information is provided in the separate-attached document.

(1) Assembly of "Toray UF TUF Rack" (Example: 2 rows x 12 modules)

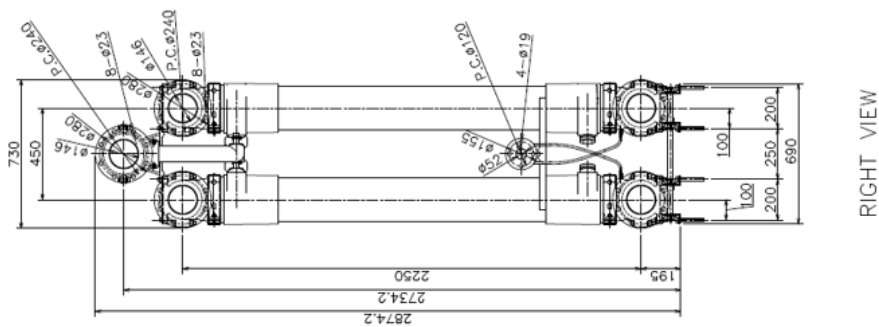

RIGHT VIEW

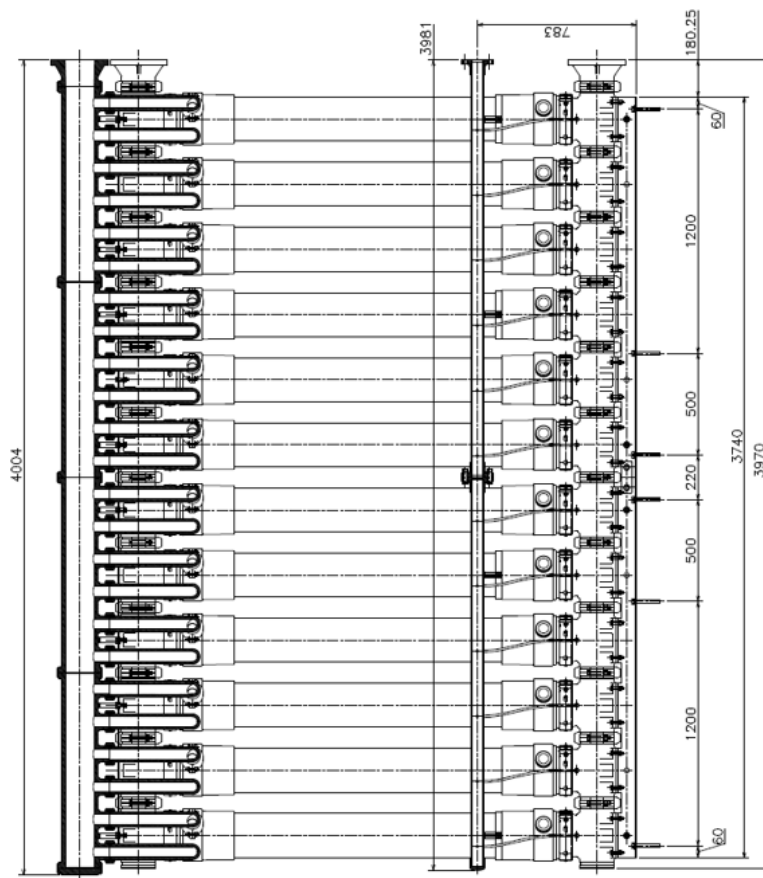

Cross Section A-A

This Instruction Manual does not intend to guarantee the results of application of the information provided herein or the safety and the compatibility of this product.

Before using this product, the user is asked to check for its safety and compatibility with the intended purpose.

The content of this Instruction Manual is subject to revision without notice due to continual improvement.

Unauthorized use or reproduction of this manual is forbidden.



Toray specializes in the development and manufacture of innovative membrane technologies. We offer an integrated approach using our RO, NF, UF, MBR, and antiscalant products to solve water and process treatment challenges. Contact us today to find out how Toray can help maximize water recovery, achieve high water quality for water reuse, lower energy requirements, and minimize life cycle costs. **TORAY, experts in RO, NF, UF and MBR.**

www.water.toray

'TORAY'
Innovation by Chemistry