

Toray UF

Instruction Manual



“HFUG-2020AN”
(type AN)

Last updated March 2023
06-G-MB2-HFUG-2020AN-230330

TORAY
Innovation by Chemistry

Notice

The data and information contained in this document are based upon rigorous technical testing by Toray, and is to the best of our knowledge reliable. Toray cannot control design and operating conditions, and consequently Toray does not assume any liability for results obtained or damage incurred through the application of the information provided herein. No liability, warranty or guarantee of final product performance by Toray is implied by the information provided in this document.

This manual supersedes all previous versions. Technical modification of products or production technology may necessitate changes to information in this manual without prior notice. Please verify that your version of the manual is the latest version available by either contacting Toray, or checking online at www.water.toray.

Terms and Conditions of Use

When using this document, please read the Terms and Conditions of Use below thoroughly and agree to them before using this document. By using this document, you agree to all of the Terms and Conditions of Use outlined here. The Terms and Conditions of Use are subject to change without prior notice, so please check with Toray for the latest Terms and Conditions of Use before using the document.

1. Intellectual Property Rights

The content in this document is protected by copyright laws in respective countries and relevant treaties. Accordingly, the document's information may not be reproduced, altered, or distributed without permission in writing from Toray. We permit downloading this document through Toray's website as a PDF file, stored on a personal computer, and printed out for customers' personal use. However, we prohibit transferring this document to any other websites or printed media. The material contained in this document may not be used without permission from the copyright holder for any other purpose that exceeds the scope permitted under copyright law.

2. Trademarks

The "TORAY" company name used in this document is a trade name, and the names of products manufactured by Toray are trademarks or registered trademarks. Toray's trade names and trademarks are protected under the Japanese Trademark Law, the Unfair Competition Prevention Law, and other legislation. The trade name and trademarks may not be used or reproduced without express permission from Toray.

3. Disclaimer

Toray takes all reasonable care in updating the information in this document. However, Toray makes no representation and warranty of any kind, either express or implied, including without limitation, any implied warranties concerning the accuracy, usefulness, suitability, or fitness for a particular purpose of the information in the document.

Toray shall not be responsible or liable for any losses or damage incurred due to the use of the information in this document. The information in this document is subject to change without prior notice, and Toray reserves the right to suspend or discontinue the publication of this document.

4. Availability of Goods and Services

The goods and services contained in this document are not available in all countries and regions. Goods and services may also be supplied under different trademarks in different countries. We ask that you contact your nearest Toray representative office if you wish to use the goods and services shown or implied in this document.

5. Proper Law and Court of Jurisdiction

This Terms and Conditions of Use shall be governed by and construed according to the laws of Japan. Any and all disputes arising out of or relating to this document shall be brought to the Tokyo District Court Tokyo, Japan.

Contact Information

Toray Industries, Inc. — UF & MBR Membrane Products Department (Global Headquarters)
Nihonbashi Mitsui Tower, 1-1, Nihonbashi-Muromachi 2 chome, Chuo-ku, Tokyo, 103-8666
Japan
Tel: +81-3-3245-4542 Fax: +81-3-3245-4913

Toray Membrane USA, Inc. (TMUS)
13435 Danielson Street, Poway, California 92064 USA
Tel: +1-858-218-2360 Fax: +1-858-218-2380

Toray Membrane Europe AG (TMEU)
Grabenackerstrasse 8b, Muenchenstein 1 CH-4142, Switzerland
Tel: +41-61-415-8710 Fax: +41-61-415-8720 E-mail: info.tmeu.mb@mail.toray

Toray Asia Pte. Ltd. (TAS)
111 Somerset Road, #14-22 - #14-27, Singapore 238164, Republic of Singapore
Tel: +65-6226-0525 Fax: +65-6226-0509

Toray BlueStar Membrane Co., Ltd. (TBMC)
Zone B, Tianzhu Airport Industrial Zone, Beijing 101318, China
Tel: +86-10-8048-5216 Fax: +86-10-8048-5217

Toray Membrane Middle East LLC (TMME)
PO Box 20279, Dammam 31952, Kingdom of Saudi Arabia
Tel: +966-13-568-0091 Fax: +966-13-568-0093

Toray Advanced Materials Korea Inc. (TAK)
Korea Toray R&D Center 7, Magokdong-ro 10-gil, Gangseo-gu, Seoul 07790, Republic of
Korea
Tel: +82-22-3279-7389 Fax: +82-2-3279-7088

website: www.water.toray

TABLE OF CONTENTS

I.	Introduction	1
1.	Characteristics of Toray "HFU series" Membrane Module	1
2.	About "type AN"	2
3.	Applications of Toray "HFU series" Membrane Module	2
II.	For Your Safety	3
1.	Safety Instruction for Unpacking and Installation	4
2.	Safety Instruction for Filtration Operation	6
3.	Safety Instruction for Chemical Cleaning	8
4.	Safety Instruction for Disposal	9
5.	Warranty Claims	10
6.	Warranty Policy	11
III.	Specifications of Toray "HFU Series" Membrane Module	12
IV.	Configuration of Toray "HFU Series" Membrane Module (type AN).....	15
V.	Installation.....	16
VI.	Operation	19
1.	Filtration	19
2.	Backwash and Air-scrubbing	21
3.	Toray Maintenance Cleaning	23
4.	Basic Trans-Membrane Pressure Calculation.....	26
5.	Temperature Correction Factor.....	27
6.	Performance Recording	28
VII.	Chemical Cleaning	29
VIII.	Storage of Membrane Module	33
1.	Storage of New Membrane Module	33
2.	Storage of Membrane Module after Use.....	33
3.	Replace Preservative Chemical	34

I. Introduction

Toray PVDF Hollow Fiber Membrane Module "HFUG series" is a pressurized hollow fiber UF (Ultra Filtration) membrane module developed with polymer science and membrane fabrication technologies accumulated over decades of successful membrane manufacturing at Toray Industries, Inc.

The membrane material is Polyvinylidene fluoride (PVDF). The nominal pore size of the membrane is 0.01 micrometers.

The module, which is permanently potted in its casing, is pressure-driven which provides equal filtrate quality to submerged modules, while offering greater TMP range for more flexible plant operation. Maximum operating pressure is 300 kPa (43.5 psi). The flow direction is outside-in, which is more suitable for higher turbidity water treatment because of the air-scrubbing effectiveness. Additionally, outside-in modules can remove suspended solids more effectively at higher recovery rates compared to inside-out fibers.

1. Characteristics of Toray "HFUG series" Membrane Modules

(1) High Filtration Flux

HFUG series provides high filtration flux and stable operation for the filtration of various raw water sources. The membrane is made with a special spinning method, which enables high permeability and high fouling resistance.

(2) Excellent Water Quality

HFUG series provides very good water quality for the filtrate, extremely low turbidity since the membrane has 0.01 micrometers nominal pore size. HFUG series is recommended to be applied to the tertiary treatment of sewage water and RO pretreatment in desalination.

(3) High Mechanical Strength

The membrane of HFUG series has very high mechanical strength because it is made of PVDF with the special spinning method developed by Toray. HFUG series provides high integrity and durability under recommended operating conditions.

(4) High Chemical Durability

The membrane material of HFUG series is PVDF, which allows to clean the membrane with high concentrations of chlorine and with high concentrations of acid resulting in better cleaning and longer sustainable membrane flux rates.

2. About “type AN”



“Type AN” is a module type whose housing is sealed with an improved cap. All connecting parts of "Type AN" modules are identical to those of "Type N" modules, so existing "Type N" modules can be replaced with "Type AN" modules.

3. Applications of Toray " HFUG-2020AN " Membrane Module



- Drinking Water Production
- Tertiary Treatment
- RO Pretreatment
- Industrial Water Production
- Reuse of Industrial Wastewater

II. For Your Safety

- Please be sure to read and follow the instructions below before using HFUG-2020AN. This manual should be retained for future reference.
- Follow the safety precautions as they are intended to protect operators and equipment from various risks such as physical harm and/or property damage. The following table shows a level of potential risk for each indicated symbol.

 DANGER	<p>This symbol indicates an imminent hazardous situation which will result in serious injury or death when the instruction is not observed.</p>
 WARNING	<p>This symbol indicates a potentially hazardous situation which will result in serious injury or death when the instruction is not observed.</p>
 CAUTION	<p>This symbol indicates a potentially hazardous situation which might result in injury or property damage when the instruction is not observed.</p>

- The following table explains the information to be noted.

 Prohibited	<p>“Prohibited”</p> <p>This symbol indicates a prohibited action or procedure.</p>
 Instruction	<p>“Instruction”</p> <p>This symbol indicates an important action or procedure which has to be taken without fail.</p>

1. Safety Instruction for Unpacking and Installation



Be sure to wear safety gear such as rubber gloves and safety glasses for unpacking. The membrane is packaged in sodium hypochlorite solution (Max. 200 mg/L as Cl₂). If the solution happens to splash onto the skin, wash the affected part with running water. If the solution happens to get in the eyes or mouth, wash the affected part with sufficient amounts of clean running water for more than 15 minutes and see the doctor immediately.



Be sure to wear safety gear such as a helmet to protect your head and safety shoes to avoid injury due to falling of related parts or equipment, such as module, etc.



The preservative solution should be drained out before using the modules. After that, fill tap water or equivalent quality water into the modules to prevent the hollow fiber membrane from drying out. Do not allow the modules to dry even for a few hours.



The membrane modules should not be frozen.



Be careful not to damage or dent the modules during handling.



Be sure to wear protective appropriate gloves to avoid injury of hands by packing box of the modules.



Housing type joints and screw are applied to connect the modules of HFUG-2020AN to the piping. Follow the instruction of the connection provided by the supplier at the connection point. Wrong connections may damage the modules.



When connecting and unconnecting the modules to the piping, be sure to secure a sufficient working space, and take care not to catch and hurt fingers.



Keep the connection surface free of any dirt or oils.



Be sure to install the modules vertically for effective air scrubbing.

2. Safety Instruction for Filtration Operation



Flush all the piping out with clean water and make sure no debris is remaining in the piping prior to connecting the modules.



Confirm that the preservative chemical in the modules is completely drained out before starting the filtration operation. The preservative chemical is harmful to humans.



Flush the modules at low pressure, filling from the bottom, and vent to remove any air from the modules. Air left in the modules may cause water hammer and may result in damage to the membrane.



Prior to use, make certain modules are flushed. Filtrate water should be drained unless it meets the required quality.



Protect modules from direct sunlight and ultraviolet light. Ultraviolet light can degrade module housing and membranes.



Constantly monitor filtrate water quality such as turbidity and/or the number of particles during filtration, and stop the operation if abnormal water quality is detected.



Prohibited

Do not exceed the maximum applicable pressure of 300 kPa (43.5 psi). Higher pressures can damage the modules. Do not exceed the maximum temperature of 40 deg C (104 deg F). The higher temperature damages the modules.



Prohibited

Do not freeze the membrane modules.



Instruction

The operating conditions, including the filtration flux and the periodical physical cleaning, must be properly set up otherwise the trans-membrane pressure may rise too quickly. The operation range is described in the latter section of this manual.



Instruction

Make sure air tubes or connected pipes are properly fixed. Otherwise, the tubes or connected pipes may be blown away or behave violently during air-scrubbing.



Instruction

Do not overfeed air to the modules. Excessive scrubbing air damages the membranes and/or shortens the membrane life.

The air flow rate should be within the range below for each module type.

HFUG-2020AN: 4.8 – 9.0 Nm³/h (2.8 – 5.3 scfm)

The maximum required air pressure during the air-scrubbing for inside of the module will be 40 kPa (6 psi).



Instruction

At the integrity tests, such as Pressure Decay Test (PDT) or Diffusive Air Flow (DAF) Test, keep the air pressure below 130 kPa (18.9 psi). Keep the source air pressure lower than 200 kPa (29 psi), to prevent excess air inflow. All the air used for air scrubbing and integrity testing must be dry oil-free air..

3. Safety Instruction for Chemical Cleaning



Instruction

Take special precautions when handling chemicals during chemical cleaning. Wear the safety gear such as safety glasses and protective appropriate gloves. If chemicals come in direct contact with your skin or your clothes, treat the contacted part appropriately based on the SDS.



Prohibited

Do not mix sodium hypochlorite with acid. Such mixture generates toxic chlorine gas.



Instruction

Stop operation whenever any anomaly occurs with the equipment or any signs of an anomaly are observed.



Instruction

In the chemical cleaning, strictly follow the procedure described in the latter section of this manual. Otherwise you may damage the modules or negatively affect the membrane performance.

4. Safety Instruction for Disposal



WARNING



Instruction

Apply a service of a qualified waste disposing company when disposing of the modules. Use the appropriate facilities in which hydrogen fluoride (HF) gas can be neutralized when the module is to be incinerated. HF gas is generated with the incineration of membrane.

5. Warranty Claims

UF modules that are damaged due to improper loading, shipping, handling, or storing shall not be covered by Toray Industries, Inc.'s warranty. Therefore, it is very important that the customer firmly follows instructions of loading, shipping, handling, and storing of the UF modules mentioned in this Instruction Manual.

UF modules which are in their original sealed package can be stored for 12 months from the date they were shipped from Toray's factory or warehouse. If they are stored for longer than 12 months, the warranty will become void unless otherwise Toray Industries, Inc. agrees.

6. Warranty Policy

Full and proper compliance with this Instruction Manual is a mandatory required thing for the claims under the warranty. In case of making a warranty claim, the customer automatically agrees to provide Toray Industries, Inc. with the information about operation mode, recording performance data of UF systems.

Kindly please contact Toray Industries, Inc. if the customer wishes to deviate from any of the procedures or specifications mentioned in this Instruction Manual and request written approval in advance. Otherwise, the customer has a risk of invalidation for any warranty claims that they may make in the future.

III. Specifications of Toray “HFUG-2020AN” Membrane Module

Table 1. Specifications of membrane *1)

Membrane Material		PVDF (Polyvinylidene fluoride)
Nominal Pore Size *2)		0.01 micrometers
Trans-Membrane Pressure	Maximum *3)	300 kPa (43.5 psi)
	Normal Operation	Lower than 200 kPa (29.0 psi)
Storage and Operating Temperature Range		1 – 40 deg C (34 – 104 deg F)
Operating pH Range		1 – 10

*1): Note that the specifications are subject to change without notice.

*2): Estimation from removal of model particles.

*3): TMP (Trans-Membrane Pressure) should be below 300 kPa (43.5 psi) at any time even during the filtration.

Table 2. Feed water limits *1), *4)

Turbidity	Intermittent Peak *5)	200 NTU
	Continuous Maximum	50 NTU
TSS	Intermittent Peak *5)	200 mg/L
	Continuous Maximum	50 mg/L
Ozone		Not detected
Pretreatment Filter Mesh Size		Smaller than 200 micrometers
Temperature Range		1 – 40 deg C (34 – 104 deg F)
pH Range		1 – 10
Maximum Feed Pressure		300 kPa (43.5 psi)

*1): Note that the specifications are subject to change without notice.

*4): If you have any concerns about design, please contact us.

*5): The duration time should be less than 48 hours and the occurrence frequency should not exceed more than once a month.

Table 3. Cleaning limits *1)

Cleaning pH Range	0 – 12
Cleaning Temperature Range	1– 40 deg C (34 – 104 deg F)
Maximum Concentration of NaClO as Cl ₂	3,000 mg/L (10 ≤ pH ≤ 12)
Maximum NaClO Exposure (Lifetime contact time) as Cl ₂	1,000,000 mg/L hours
Maximum Acid Contact Time	1,000 hours (pH ≥ 0)

*1): Note that the specifications are subject to change without notice.

Table 4. Specifications of modules *1)

Module Type		HFUG-2020AN
Membrane Surface Area (Outer Surface)		90 m ² (969 ft ²)
Dimensions	Diameter	216 mm (8.50 inches)
	Length	2,160 mm (7.087 ft.)
Weight	Full of Water	92 kg (203 lbs)
	Drained	49 kg (108 lbs)
Materials	Housing	PVC and/or equivalent
	Potting	Epoxy and/or equivalent
Connections	Top	Housing type joint 80A
	Bottom	Housing type joint 80A
	Side	Housing type joint 65A
Operating Conditions	Max. Feed Water Flow	15 m ³ /h (66 gpm)
	Max. Backwash Flow	16.8 m ³ /h (74 gpm)
	Max. Air Flow	9.0 Nm ³ /h (5.3 scfm)
	Filtration Method	Outside to inside, dead end
	Max. Inlet Pressure	300 kPa (43.5 psi)
	Maximum Temperature	40 deg C (104 deg F)

*1): Note that the specifications are subject to change without notice.

**CAUTION**

- Handle and operate the modules within the ranges and the limits indicated in Table 1 to 4. Operation out of these ranges or limits may damage the modules and affect filtration performance.

IV. Configuration of Toray “HFUG-2020AN” Membrane Module

- (1): Filtrate Outlet / Inlet of Backwash Water
- (2): Air Outlet / Backwash Water Outlet
- (3): Feed Water Inlet / Air Inlet / Drain Outlet

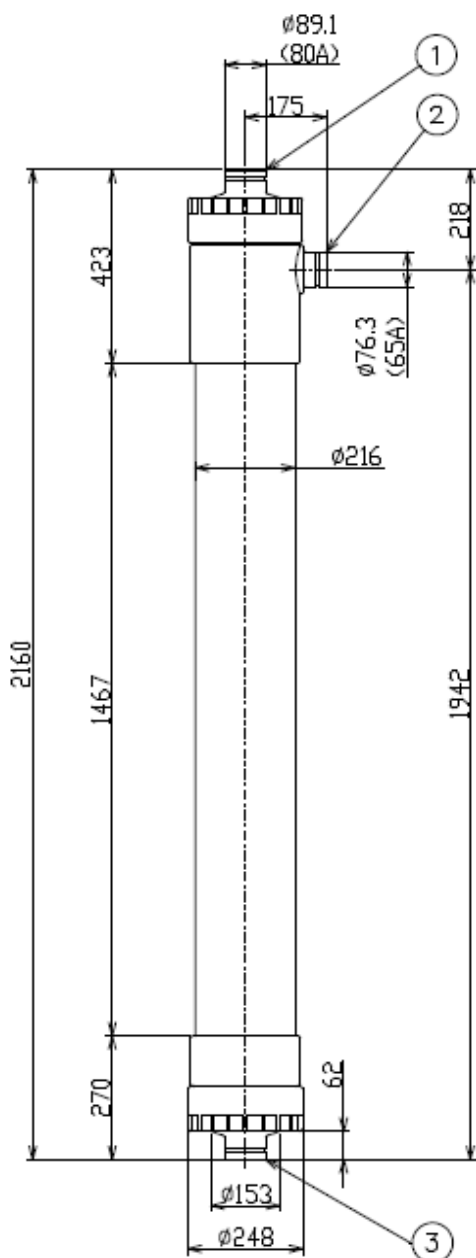

Connections

	Pipe fitting outer diameter mm (in)	Connectors
(1)	89.1 (3 1/2")	Housing type joint 80A
(2)	76.3 (3")	Housing type joint 65A
(3)	89.1 (3 1/2")	Housing type joint 80A

Fig. 1. Type: HFUG-2020AN

V. Installation

The standard procedure to install membrane modules is described below.

1. Unpack membrane module from a wooden box or corrugated box.



CAUTION

- Be sure to wear protective appropriate gloves to avoid injury of hands by packing box of the modules.

2. Remove a plugging plate from each nozzle of the module.

3. Drain out the preservative solution from the module.



DANGER

- Wear rubber gloves and safety glasses when you drain the preservative chemical. Note that the preserving chemical is sodium hypochlorite solution (Max. 200 mg/L as Cl₂). If this solution splashes onto your skin, wash the affected part with running water. If the solution gets in your eyes or mouth, wash the affected part with enough amounts of running water for over 15 minutes and see the doctor immediately.

4. Put the module vertically on the pedestal in the module rack. Fix the module upright with the hanging hook and/or the supporting belt. (see Fig. 2).

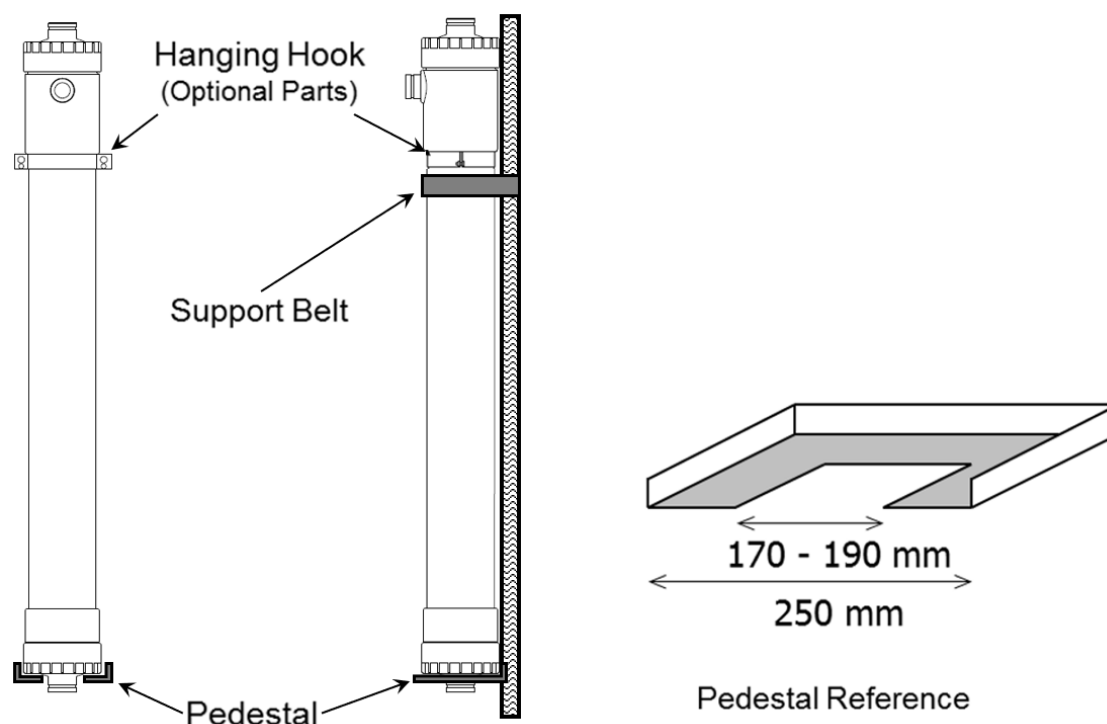

Fig. 2. Typical example of the membrane module installation

	WARNING	<ul style="list-style-type: none"> ● Do not drop the module. ● Use equipment such as chain blocks, a crane, or a forklift truck when you handle the module. The HFUG-2020AN module is too heavy to handle by hand.
	CAUTION	<ul style="list-style-type: none"> ● Take care not to catch and hurt fingers. ● Be careful not to install the module upside down. Confirm the module is installed in the right direction. ● Do not overtighten the module with the hanging hook and/or the supporting belt, or you may damage the module. ● Do not allow the hollow fiber membranes to dry even for a few hours, especially in summer. ● Do not freeze the module.

5. Connect the piping to each connection point of the module with Housing type joints (HFUG-2020AN) (see Fig. 4). The maximum fastening power of the Housing type joints should not exceed 40 Nm. When you tighten or loosen the Housing type joints, make certain to maintain sufficient space prior to the work and be careful not to injure one's fingers or other body parts.

**CAUTION**

- Keep the connection surface free of any dirt or oils.
- Follow the instruction below when storing the modules.
A wrong use may cause the damage to the module.

6. Air inject should be located just beneath the bottom nozzle of the module to inlet air completely to the module. Please refer to the below photos (see Fig. 3). Also, a check valve is necessary to the air piping to avoid water reverse flow.



Good location for air inject



Poor location for air inject

Good location for check valve

Fig. 3. Typical example of the air pipe installation

**WARNING**

- Make sure air tubes or connected pipes are properly fixed. Otherwise, the tubes or connected pipes may be blown away or behave violently during air scrubbing.

7. Make sure that the module is installed vertically.

**CAUTION**

- If the module is not installed vertically, the effect of the air scrubbing would be reduced, and an effective filtration will be impaired.

VI. Operation

1. Filtration

- (1) Check that all piping is connected appropriately and flushed out prior to the operation. Fig. 4 shows a typical example of membrane pipe connection.

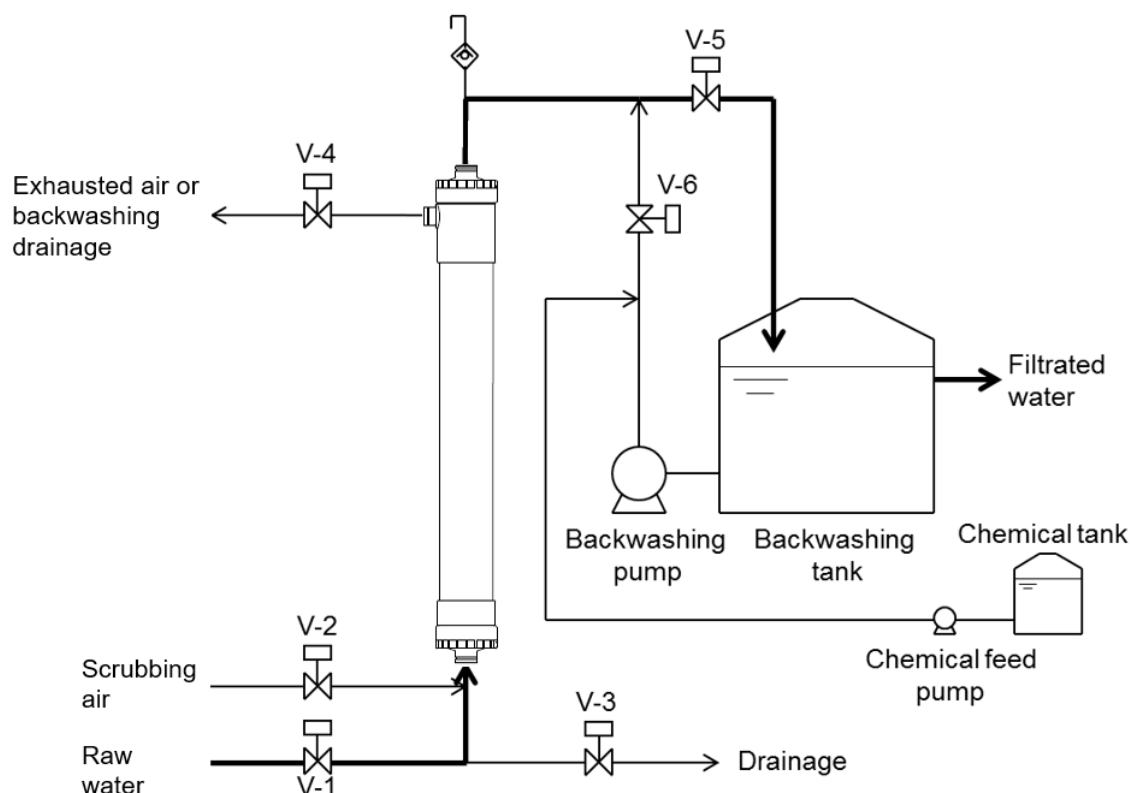

Fig. 4. Typical example of membrane pipe connection

- (2) Make sure the feed water valve (V-1), the drainage valve (V-3), and the valve for the scrubbing air (V-2) are “closed”.
- (3) Make sure the filtrate water valve (V-5) is opened. Open the air exhaust valve (V-4).
- (4) Gradually open the feed water valve (V-1) and fill the feed water to the module to purge any air out.



CAUTION

- Do not open the feed water valve (V-1) quickly, or water-hammer may occur, and the module could be damaged.

-
- (5) Confirm that the air is out of the module, and then close the air exhaust valve (V-4).
- (6) Set appropriate volume of filtrate water flow.

**CAUTION**

- Do not exceed 300 kPa (43.5 psi) to avoid damage to the module.
- Operating conditions including the filtration flux and the physical cleaning should be properly set up to observe the rise of trans-membrane pressure (Details are described in the next session). Please contact us for any technical support if necessary.

- (7) When stopping the operation, gradually close the feed water valve (V-1).

2. Backwash and Air-scrubbing

The physical cleaning with backwash followed by air-scrubbing should be carried out periodically and automatically for the continuous filtration. The frequency of the physical cleaning mainly depends on the raw water quality (Typical frequency is once every 30 minutes for the surface water filtration. Please contact us if you need any technical support). Fig. 5. shows a typical example of the flow diagram for backwash and air-scrubbing.

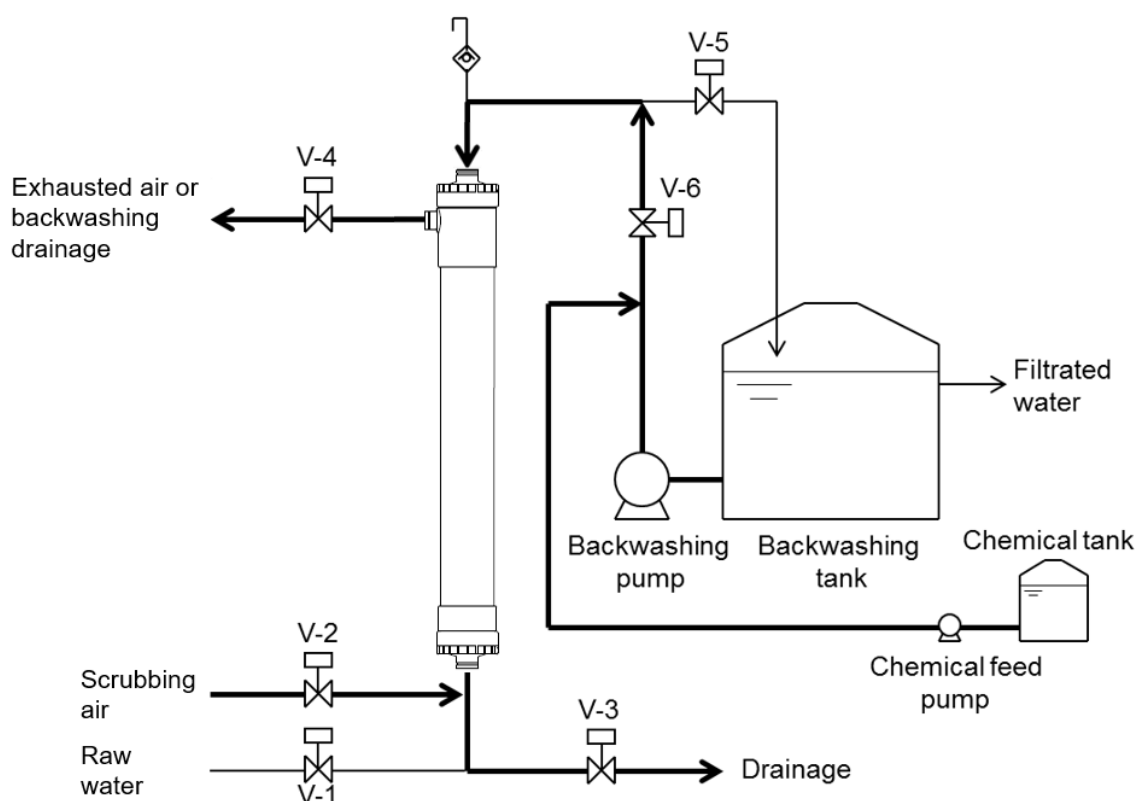

Fig. 5. Flow diagram for backwash and air-scrubbing

- (1) Close the feed water valve (V-1) and stop the feed water pump.
- (2) Open the air exhaust valve (V-4).
- (3) Close the filtrate water valve (V-5) and open the backwashing valve (V-6) to feed back the filtrate water from the backwashing tank to the membrane module. During backwash, the chemical feed pump can be operated to dose chemical to the backwash water. The chemical is usually sodium hypochlorite, and the dosing rate should be up to 50 mg/L as Cl_2 .

The flow rate of backwash water is set up in advance for 1.0 to 1.5 times the filtrate flow rate. Do not exceed Max. Backwash Flow described in Table 4.

- (4) After backwashing for a fixed time (normally 30 seconds, up to 60 seconds), close the backwashing valve (V-6) and stop the backwashing pump.
- (5) Open the air exhaust valve (V-4) and the air-scrubbing valve (V-2) for air-scrubbing for a fixed time (normally 30 seconds, up to 60 seconds).

**CAUTION**

- The air flow rate for air-scrubbing should be within the range below. Excessive air flow rate may damage the hollow fiber membrane.

HFUG-2020AN: 4.8 – 9.0 Nm³/h, normally 6.0 Nm³/h
(2.8 – 5.3 scfm, normally 3.5 scfm)

The maximum required air pressure during the air-scrubbing for the inside of the module will be 40 kPa (6 psi).

- (6) Close the air-scrubbing valve (V-2) and open the drainage valve (V-3).
- (7) Close the drainage valve (V-3) after the water is all drained out.
- (8) Run the feed water pump and open the feed water valve (V-1).
- (9) Close the air exhaust valve (V-4) after the air is purged from the module.

**CAUTION**

- Constantly monitor filtrate water quality during filtration and stop the operation if abnormal water quality is detected. In that case, check the integrity of the element with PDT (Pressure Decay Test) or DAF (Diffusive Air Flow) Test. The test procedure is provided as the technical information by Toray.

3. Toray Maintenance Cleaning

Instead of chemical dosing for every backwash, soaking the membrane in a chemical solution several tens of minutes a day is also effective for membrane performance retention. This process is called Toray Maintenance Cleaning (TMC). The TMC is usually held following the backwash and air-scrubbing which does not contain the chemical dosing. The frequency and soaking time of the TMC mainly depends on the raw water quality (Normally once a day for 20 minutes. Please contact us if you need any technical support.). Fig. 6 shows a typical example of flow diagram for the TMC.

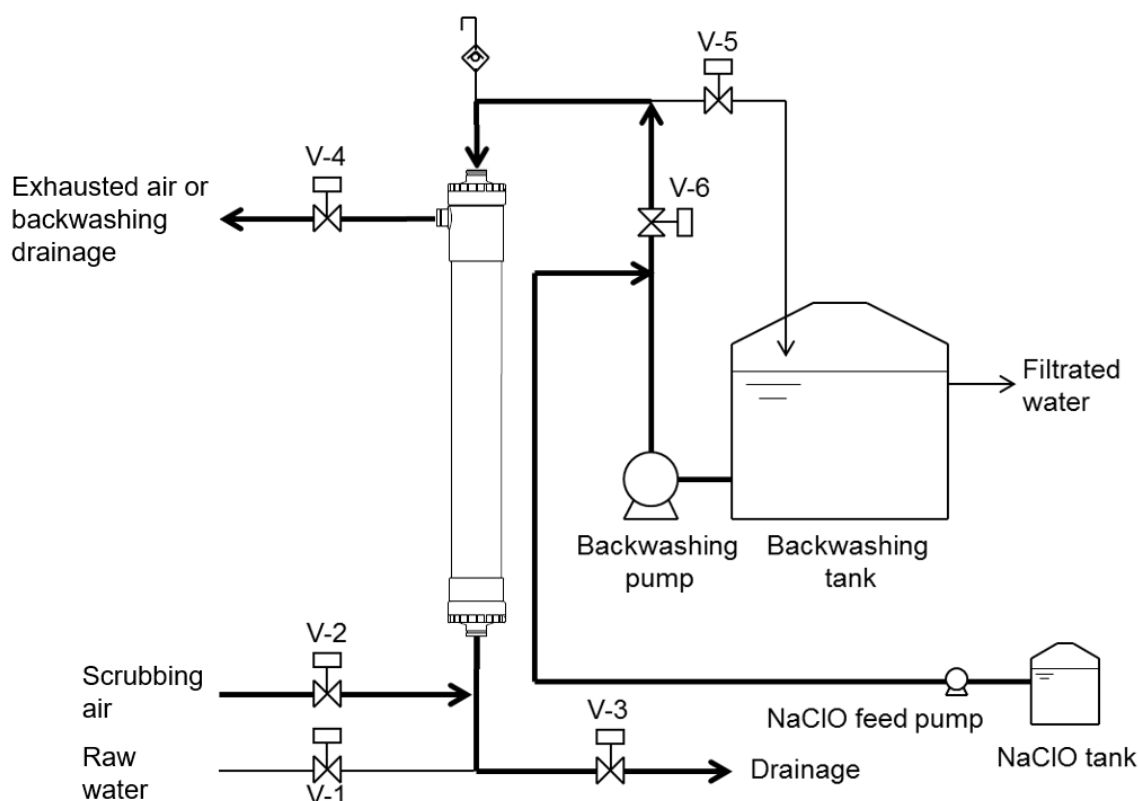

Fig. 6. Flow diagram for the TMC

- (1) Open the air exhaust valve (V-4) and the drainage valve (V-3).
- (2) Open the backwashing valve (V-6), run the NaClO feed pump and the backwashing pump to feed the chemical enhanced backwash water to the membrane module. The chemical is usually sodium hypochlorite, and the dosing rate should be up to 300 mg/L as Cl_2 for TMC.
The flow rate of backwash water is set up in advance for 1.0 to 1.5 times the filtrate flow rate. Do not exceed Max. Backwash Flow described in Table 4.

- (3) As soon as the NaClO is detected in the drainage water, close the drainage valve (V-3). NaClO diluted with UF filtered water is applied to TMC cleaning solution usually. In this case, if the filtered water contains a lot of organic matter, NaClO will be consumed by the organic matter, which may result in a substantial decrease of cleaning efficiency. Please contact us if there is such concern.
- (4) After making sure water comes out from the upper part of the side nozzle of the membrane module, stop the NaClO feed pump, close the backwashing valve (V-6), and stop the backwashing pump.
- (5) Soak the membrane in the chemical for a fixed time (normally 20 minutes). And then, open the air-scrubbing valve (V-2) for a fixed time (normally 60 seconds).

**CAUTION**

- The air flow rate for air-scrubbing should be within the range below. Excessive air flow rate may damage the hollow fiber membrane.

HFUG-2020AN: 4.8 – 9.0 Nm³/h, normally 6.0 Nm³/h
(2.8 – 5.3 scfm, normally 3.5 scfm)

The maximum required air pressure during the air-scrubbing for the inside of the module will be 40 kPa (6 psi).

- (6) Close the air-scrubbing valve (V-2), open the drainage valve (V-3) to drain the chemical from the membrane module.
- (7) Close the drainage valve (V-3), open the backwashing valve (V-6), and run the backwashing pump (normally 30 seconds). Stop the backwashing pump, close the backwashing valve (V-6), and then open the air-scrubbing valve (V-2) (normally 30 seconds). Repeat this procedure until the overflow water meets the required water quality.
- (8) Repeat the process of (6) to (7) until the overflow water meets the required water quality.
- (9) Make sure the air-scrubbing valve (V-2) and the backwashing valve (V-6) are “closed” and the backwashing pump is “stopped”.

**CAUTION**

- Constantly monitor filtrate water quality during filtration and stop the operation if abnormal water quality is detected. In that case, check the integrity of the element with PDT (Pressure Decay Test) or DAF (Diffusive Air Flow) Test. The test procedure is provided as the technical information by Toray.

4. Basic Trans-Membrane Pressure Calculation

To calculate accurate Trans-Membrane Pressure (TMP), it is necessary to involve the height difference of inlet and outlet pressure gauges (see Fig. 7).

Example calculation of TMP (The specific gravity of water is set to 1)

$$\begin{aligned} \text{TMP} &= (P_{\text{in}} - H_{\text{in}}) - (P_{\text{out}} - H_{\text{out}}) \\ &= (70 - 10) - (20 - (-25)) \\ &= 60 - 45 \\ &= 15 \text{ kPa} \end{aligned}$$

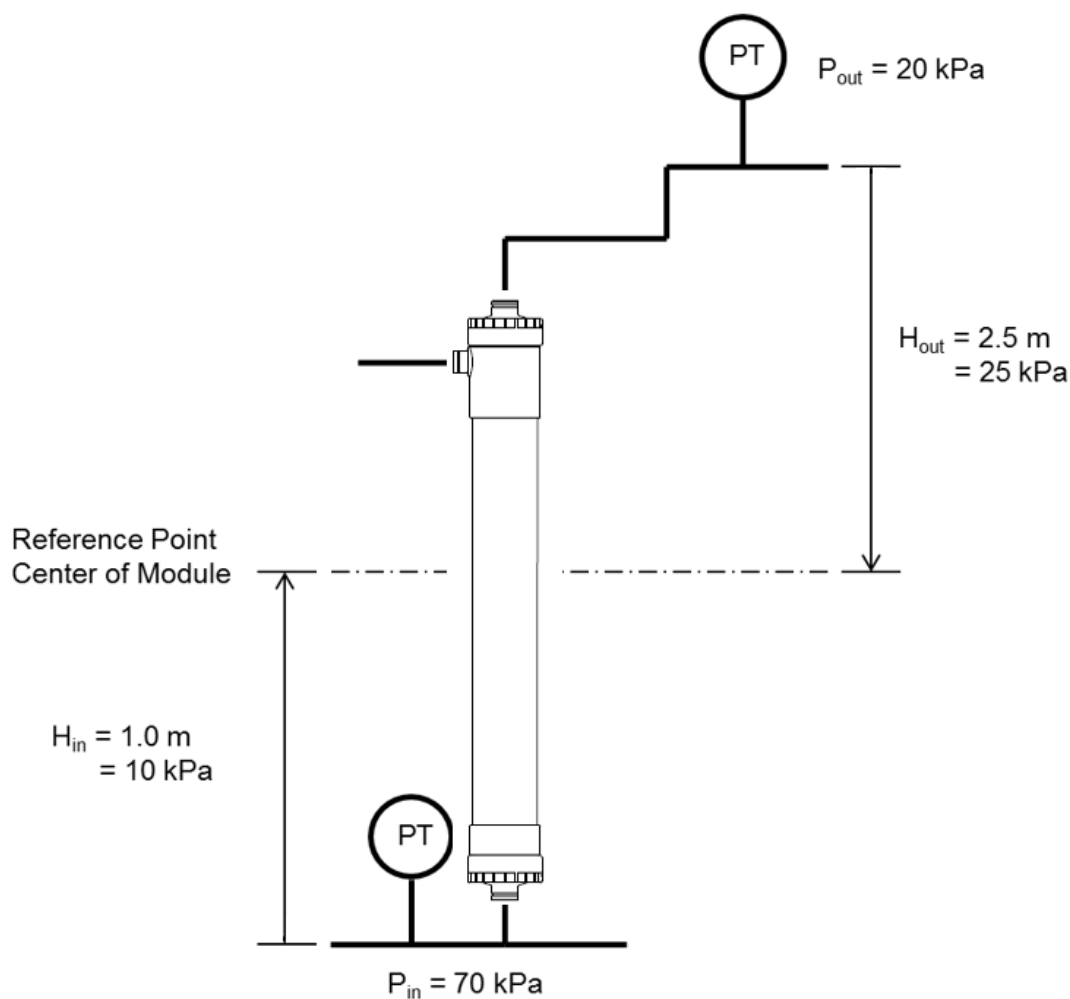

Fig. 7. Basic TMP calculation

Note, the following formula may also be used:

$$\begin{aligned} \text{TMP} &= P_{\text{in}} - P_{\text{out}} - \text{total delta H} \\ &= 70 - 20 - (10 - (-25)) = 15 \text{ kPa} \end{aligned}$$

5. Temperature Correction Factor

The permeability of the membrane is influenced by temperature mainly because the water viscosity changes with temperature. It is necessary to eliminate the temperature effect with the temperature correction factor (TCF) shown in Fig. 8 to evaluate the permeability correctly.

A Trans-Membrane Pressure (TMP) measured at some real temperature can be converted to 25 deg C corrected TMP with multiplying by TCF at real temperature.

A filtrate flow rate measured at some real temperature can be converted to 25 deg C corrected filtrate flow rate with divided by TCF at real temperature.

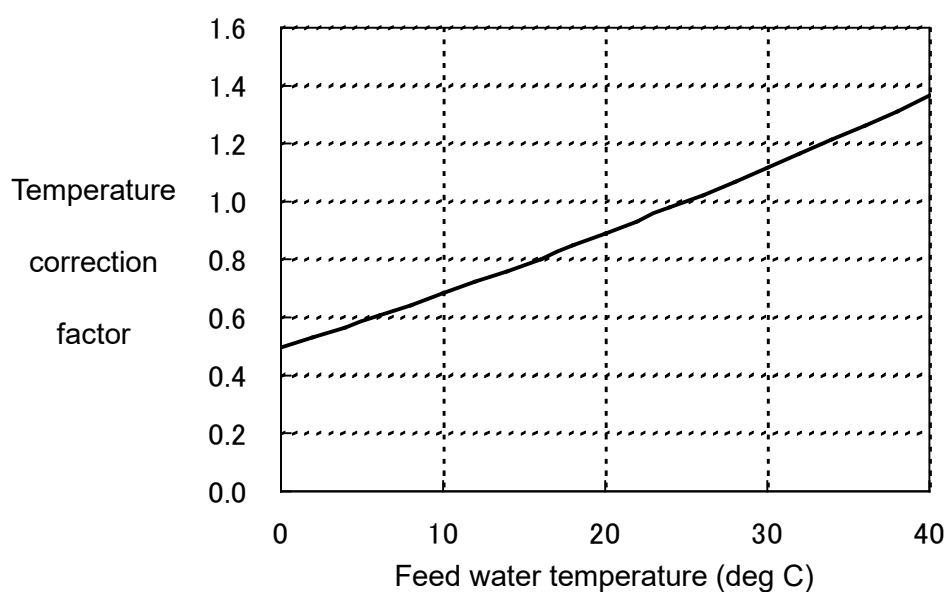

Fig. 8. Temperature correction factor (TCF)

The equation for calculating TCF at a temperature (T deg C) is as follows.

$$\text{TCF} = \frac{0.0008902}{(0.01257187 \times \text{EXP}((1 - 0.005806436 \times (273.15 + T))) / (0.001130911 \times (273.15 + T) - 0.000005723952 \times (273.15 + T) \times (273.15 + T))) / 1000}$$

6. Performance Recording

To effectively evaluate the current UF system performance, including quick recognition of undesirable trends in operation and appropriate countermeasures, it is necessary to compare current operating performance data with a performance data which were recorded at the first placed in service. Log the data which is concerned about the UF operation and must include regular information on: flow, trans-membrane pressure, contractually specified feed water quality parameters and temperature, and elapsed time since start-up (days). The data might be captured and logged automatically every 2 seconds to help optimize the UF operation system.

VII. Chemical Cleaning

The chemical cleaning should be carried out to remove foulants accumulated in the membrane pores or sticking to the membrane surface.



CAUTION

- Carry out the chemical cleaning before the trans-membrane pressure rises to 200 kPa (29.0 psi), or the module filtration performance could be reduced significantly.
- Follow the instruction described in this manual when you carry out the chemical cleaning. If you use the unacceptable chemicals or perform the cleaning altered from the recommended procedure, the membrane could be seriously damaged.



DANGER

- Pay full attention when handling chemicals and be sure to wear the safety gear such as glasses and gloves. The chemicals used for the chemical cleaning are harmful to people. If chemicals directly contact your skin, your eyes, or other body parts, take the appropriate treatment as stated in its SDS.
- Do not mix sodium hypochlorite with acid. Such mixture generates toxic chlorine gas.
- Stop operations when any instrumental anomalies occur, or any sign of anomalies are observed.

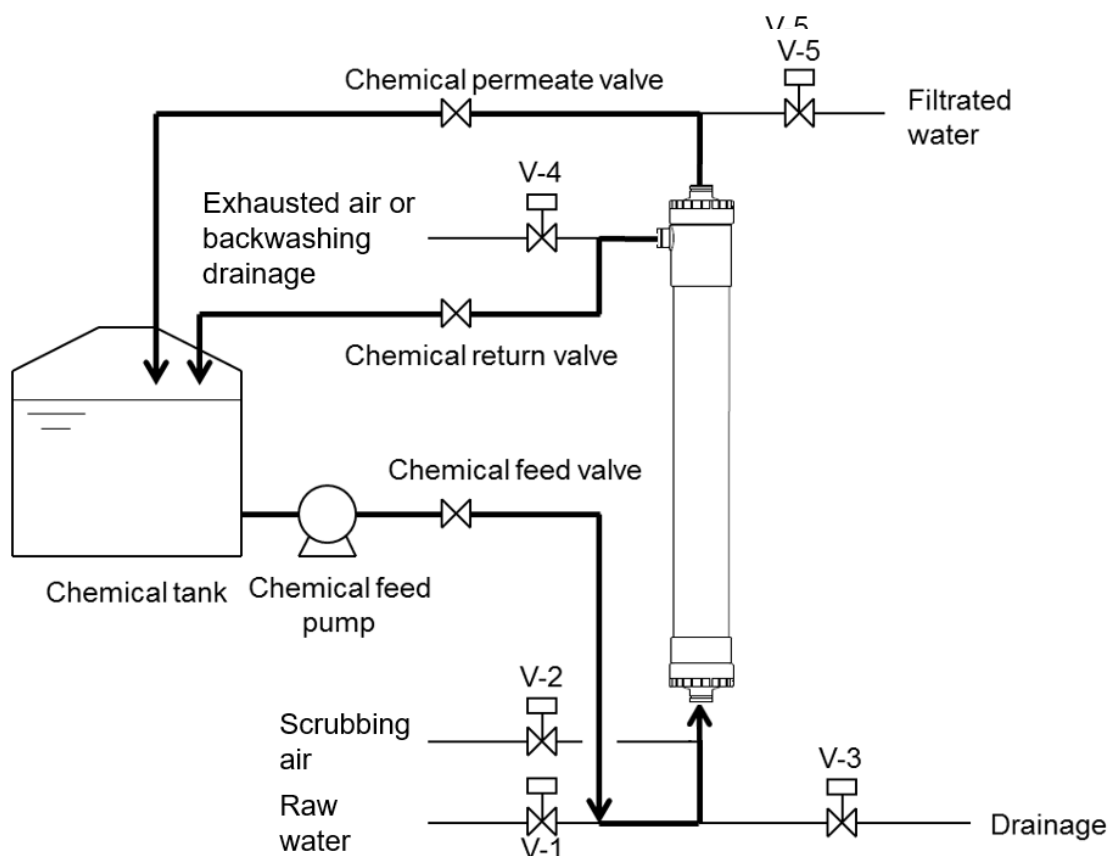

Fig. 9. Flow diagram for chemical cleaning

- (1) The flow diagram for cleaning simultaneously both outer surface and inside of hollow fiber membranes is shown in Fig. 9. The flow diagram can be changed case by case. Please contact us for further information if necessary.
- (2) Open the chemical return valve and then open the chemical feed valve.
- (3) Run the chemical feed pump to start for chemical circulation. Then, open the chemical permeate valve to let the chemical pass through the membrane.
- (4) Circulate the chemical for a fixed time.
- (5) Stop the chemical feed pump.
- (6) Drain the chemical and rinse the cleaning line and the module thoroughly with product water.

**CAUTION**

- Take appropriate measures to prevent the mis-operation or accidents that could cause the chemicals to get into the product water. Check the piping and correctly position of each valve before starting the chemical cleaning.

(7) The standard conditions for chemical cleaning are shown in Table 5.

- The concentration and the circulation time shown in Table 5 should be observed. Otherwise, the membrane module may get damaged and/or the life of membrane may be shortened.
- The cleaning temperature should be 20 to 40 deg C.
- The circulation flow rate for each type of the module is as follows.

HFUG-2020AN: 62.5 L/min (16.5 gpm)

Table 5 Standard conditions for chemical cleaning

Pollutants	Chemicals	Maximum Concentration	Circulation Time (hr)
Inorganic substances	Citric acid *6)	3.0 wt%	1 - 3
Organic substances	Sodium hypochlorite	3,000 mg/L as Cl ₂ (10 ≤ pH ≤ 12)	1 - 3

*6): Besides citric acid, hydrochloric acid (with the maximum concentration of 1.0 mol/L), oxalic acid (with the maximum concentration of 1.0 wt%), sulfuric acid (with the maximum concentration of 0.05 mol/L), and nitric acid (with the maximum concentration of 0.1 mol/L) are acceptable.

**CAUTION**

- In the case of cleaning with acid and with sodium hypochlorite alternately, rinse the cleaning line and the module with clean water thoroughly after each cleaning. Use product water for rinsing and make sure that pH of the water in the module is in the range between pH 6.5 and 7.5 after rinsing.

**DANGER**

- Do not use any other chemicals than those indicated above.
- Do not mix sodium hypochlorite with acid. Such mixture generates toxic chlorine gas.



Instruction

The chemical cleaning should be done at least once a year. Otherwise, the module filtration performance could be reduced.

VIII. Storage of Membrane Module

Follow the instruction below when you store the modules.



CAUTION

- Be careful not to freeze the modules.

1. Storage of New Membrane Module

Keep the modules in the original packing in a dark and cool place (1 to 40 deg C). Avoid direct sunlight and moisture.

2. Storage of Membrane Modules after Use

(1) Short-term, or temporary shutdown or storage

In the case of the suspension of operation for less than four days, stop the feed water and keep modules full of water. Keep the modules at 1 to 40 deg C.

If suspended from four days to less than eight days, fill the module with the chemical described in Table 6. Use filtrate quality water. Keep the modules at 1 to 40 deg C.

Table 6. Conditions for storing membrane modules for less than eight days

Maximum Storage Period	Chemical	Concentration of the Chemical
7 days	Sodium hypochlorite	20 mg/L as Cl ₂

(2) Long-term storage

First, carry out a chemical cleaning with sodium hypochlorite. Fill the module with the chemical described in Table 7. Use filtrate quality water. Follow the instructions shown in Table 6.

Keep the modules sealed with the aqueous chemical solution shown in Table 6 or Table 7. If removing modules from the system, seal them and store out of direct sunlight. Keep the modules at 1 to 40 deg C.

Table 7. Conditions for storing membrane modules for more than seven days

Storage Period	Preservative Chemical ^{*8)}	Concentration of the Chemical
More than 7 days	Sodium hypochlorite	10 mg/L as Cl ₂ ^{*9)}
	Sodium bisulfite	1,000 mg/L

*8): Select either sodium hypochlorite or sodium bisulfite chemical solution.

*9): Be careful not to exceed the sodium hypochlorite contact upper limit shown in Table 3.



DANGER

- Rinse the module thoroughly with clean water after the chemical cleaning with sodium hypochlorite and fill the module with sodium bisulfite solution. Toxic chlorine gas is generated in the case of mixing sodium hypochlorite with sodium bisulfite without first flushing with water.

3. Replace Preservative Chemical

Check the pH value of sodium bisulfite solution as the preservative and replace the chemical if the pH is below three (3.0). Sodium bisulfite solution with a pH of 3 to 6 is active for the preservation. Sodium bisulfite reacts with oxygen and forms sulfuric acid which results in a lower pH. In case that sodium hypochlorite is being used as the preservative, replace it if the sodium hypochlorite concentration is less than 0.1mg/L as Cl₂.



Toray specializes in the development and manufacture of innovative membrane technologies. We offer an integrated approach using our RO, NF, UF, MBR, and antiscalant products to solve water and process treatment challenges. Contact us today to find out how Toray can help maximize water recovery, achieve high water quality for water reuse, lower energy requirements, and minimize life cycle costs. **TORAY, experts in RO, NF, UF and MBR.**

www.water.toray

'TORAY'
Innovation by Chemistry