

Toray MBR

Instruction Manual



“NHPA Series C type”
[050-1C, 100-1C,
150-1C, 2C, 3C and 4C]

‘TORAY’
Innovation by Chemistry

Notice

The data and information contained in this document are based upon rigorous technical testing by Toray, and is to the best of our knowledge reliable. Toray cannot control design and operating conditions, and consequently Toray does not assume any liability for results obtained or damage incurred through the application of the information provided herein. No liability, warranty or guarantee of final product performance by Toray is implied by the information provided in this document.

This manual supersedes all previous versions. Technical modification of products or production technology may necessitate changes to information in this manual without prior notice. Please verify that your version of the manual is the latest version available by either contacting Toray, or checking online at www.water.toray.

Terms and Conditions of Use

When using this document, please read the Terms and Conditions of Use below thoroughly and agree to them before using this document. By using this document, you agree to all of the Terms and Conditions of Use outlined here. The Terms and Conditions of Use are subject to change without prior notice, so please check with Toray for the latest Terms and Conditions of Use before using the document.

1. Intellectual Property Rights

The content in this document is protected by copyright laws in respective countries and relevant treaties. Accordingly, the document's information may not be reproduced, altered, or distributed without permission in writing from Toray. We permit downloading this document through Toray's website as a PDF file, stored on a personal computer, and printed out for customers' personal use. However, we prohibit transferring this document to any other websites or printed media. The material contained in this document may not be used without permission from the copyright holder for any other purpose that exceeds the scope permitted under copyright law.

2. Trademarks

The "TORAY" company name used in this document is a trade name, and the names of products manufactured by Toray are trademarks or registered trademarks. Toray's trade names and trademarks are protected under the Japanese Trademark Law, the Unfair Competition Prevention Law, and other legislation. The trade name and trademarks may not be used or reproduced without express permission from Toray.

3. Disclaimer

Toray takes all reasonable care in updating the information in this document. However, Toray makes no representation and warranty of any kind, either express or implied, including without limitation, any implied warranties concerning the accuracy, usefulness, suitability, or fitness for a particular purpose of the information in the document.

Toray shall not be responsible or liable for any losses or damage incurred due to the use of the information in this document. The information in this document is subject to change without prior notice, and Toray reserves the right to suspend or discontinue the publication of this document.

4. Availability of Goods and Services

The goods and services contained in this document are not available in all countries and regions. Goods and services may also be supplied under different trademarks in different countries. We ask that you contact your nearest Toray representative office if you wish to use the goods and services shown or implied in this document.

5. Proper Law and Court of Jurisdiction

This Terms and Conditions of Use shall be governed by and construed according to the laws of Japan. Any and all disputes arising out of or relating to this document shall be brought to the Tokyo District Court Tokyo, Japan.

Contact Information

Toray Industries, Inc. — UF & MBR Membrane Products Department (Global Headquarters)
Nihonbashi Mitsui Tower, 1-1, Nihonbashi-Muromachi 2 chome, Chuo-ku, Tokyo, 103-8666
Japan
Tel: +81-3-3245-4542 Fax: +81-3-3245-4913

Toray Membrane USA, Inc. (TMUS)
13435 Danielson Street, Poway, California 92064 USA
Tel: +1-858-218-2360 Fax: +1-858-218-2380

Toray Membrane Europe AG (TMEU)
Grabenackerstrasse 8b, Muenchenstein 1 CH-4142, Switzerland
Tel: +41-61-415-8710 Fax: +41-61-415-8720 E-mail: info.tmeu.mb@mail.toray

Toray Asia Pte. Ltd. (TAS)
111 Somerset Road, #14-22 - #14-27, Singapore 238164, Republic of Singapore
Tel: +65-6226-0525 Fax: +65-6226-0509

Toray BlueStar Membrane Co., Ltd. (TBMC)
Zone B, Tianzhu Airport Industrial Zone, Beijing 101318, China
Tel: +86-10-8048-5216 Fax: +86-10-8048-5217

Toray Membrane Middle East LLC (TMME)
PO Box 20279, Dammam 31952, Kingdom of Saudi Arabia
Tel: +966-13-568-0091 Fax: +966-13-568-0093

Toray Advanced Materials Korea Inc. (TAK)
Korea Toray R&D Center 7, Magokdong-ro 10-gil, Gangseo-gu, Seoul 07790, Republic of
Korea
Tel: +82-22-3279-7389 Fax: +82-2-3279-7088

website: www.water.toray

TABLE OF CONTENTS

I.	INTRODUCTION	1
1.	Features of MBR	1
2.	Outline of “NHPA Series”	2
II.	FOR SAFE OPERATION OF “NHPA SERIES”	5
1.	Safety Instruction for Unpacking and Installation.....	5
2.	Safety Instruction for Operation and Maintenance.....	6
3.	Safety Instruction for Chemical Cleaning of Element	8
III.	SPECIFICATIONS AND PERFORMANCE OF “NHPA SERIES”	10
1.	Specifications of Element	10
2.	Specifications of Filtrate Tube Assembly	10
3.	Specifications and Performance of “NHPA Series” Module.....	10
IV.	MEMBRANE FILTRATION PROCESS DESIGN FOR “NHPA SERIES”	15
1.	Standard Time Chart	15
2.	Flow Diagram of Membrane Filtration	16
3.	Layout of “NHPA Series” Modules in Membrane Tank.....	21
4.	Piping.....	24
V.	INSTALLATION OF “NHPA SERIES”	28
1.	Preparatory Procedure	28
2.	Unloading/Lifting Products	28
3.	Checking Products	29
4.	Storing Products	29
5.	Installing Products	30
VI.	START OF OPERATION	33
1.	Clean Water Operation.....	33
2.	Seeding Sludge Injection.....	34
3.	Actual Filtration Operation.....	35
VII.	OPERATION CONTROL	36
1.	Standard Operating Conditions.....	36
2.	Operating Parameters	38
3.	Basic Control Philosophy	38
4.	Daily Inspection	40
VIII.	MAINTENANCE OF “NHPA SERIES”	43
1.	Maintenance Items and Maintenance Frequency.....	43
2.	Air Diffuser Cleaning.....	44
3.	Chemical Cleaning of Element.....	46
4.	Chemical Agents Available for Chemical Cleaning.....	46
5.	Handling of Chemical Agents	47
6.	Chemical Cleaning Procedure.....	50

7.	Lifting Procedure	55
8.	Storing Products after Use	56
9.	Disposing Procedure	57
IX.	REPLACEMENT PARTS LIST	58
X.	TROUBLESHOOTING	59
XI.	WARRANTY POLICY	60
XII.	REFERENCE	61

Symbols used in this manual



DANGER

This symbol is used to indicate an imminent hazardous situation which, if not avoided, will result in serious injury or death.



WARNING

This symbol is used to indicate a potentially hazardous situation which, if not avoided, can result in serious injury or death.



CAUTION

This symbol is used to indicate a potentially hazardous situation which, if not avoided, may result in injury or property damage.



Prohibited

“Prohibited”

This symbol indicates a prohibited action or procedure.



Instruction

“Instruction”

This symbol indicates an important action or procedure which has to be taken without fail.

I. INTRODUCTION

Toray MBR is the submerged membrane module suitable for the membrane bioreactor (MBR) that has been developed based on the polymer science and the membrane fabrication technologies accumulated for a long time in Toray Industries, Inc.

"NHPA Series" is a new model of NHP-MBR module equipped with thin membrane elements having higher packing density, while reliable performance of Toray PVDF membrane has been kept unchanged.

This manual explains MBR's features and describes the specifications of "NHPA Series" and its safe operations including installation, operation, maintenance procedures and peripheral equipment. Operators should thoroughly read this manual to ensure stable operation.

1. Features of MBR

The process flow of the conventional activated sludge system (CAS) and MBR are shown in Fig.I-1 and Fig.I-2, respectively.

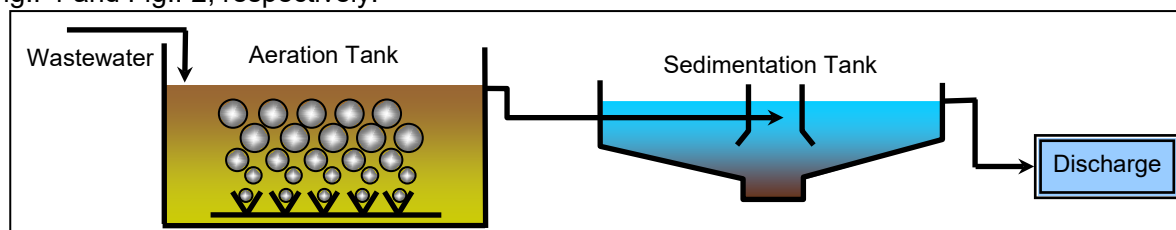

Fig. I-1 CAS Flow

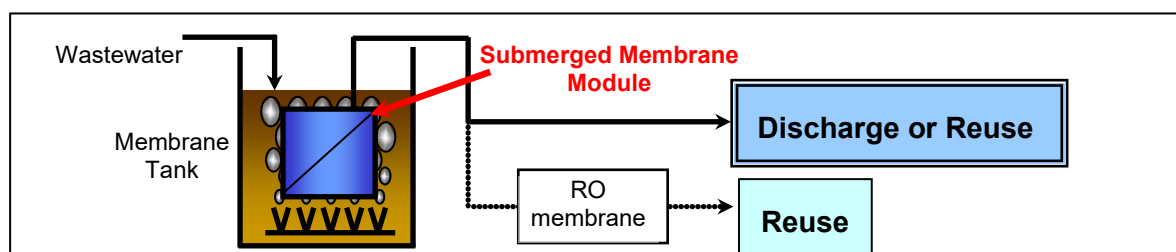

Fig. I-2 MBR Flow

MBR provides the following advantages:

(1) Small Footprint

Unlike CAS, MBR separates sludge within an aeration tank using membranes, thus eliminating the space for the sedimentation tank. Also with membrane, MBR can hold higher concentration of activated sludge in the aeration tank, so its volume can be reduced. As a result, MBR requires a smaller footprint compared to CAS.

(2) High Quality of Treated Water

MBR removes suspended solids (SS) from the sludge liquid with membrane much more certainly than the conventional sedimentation process. MBR also rejects microorganisms such as *Escherichia coli* and *Cryptosporidium* efficiently.

2. Outline of “NHPA Series”

“NHPA Series” is the membrane module composed of the element block and the aeration block. The element block contains several cassettes, and in the cassette the membrane elements, each of which consists of two flat membrane sheets, are arranged at a constant clearance. Each element is connected via plastic tube to the filtrate water manifold. For this -C model, the aeration block consists of coarse-bubble air diffusers to supply scouring air (see Fig.I-3).

This module is used submerged in sludge liquid.

The following shows the features of “NHPA Series”.

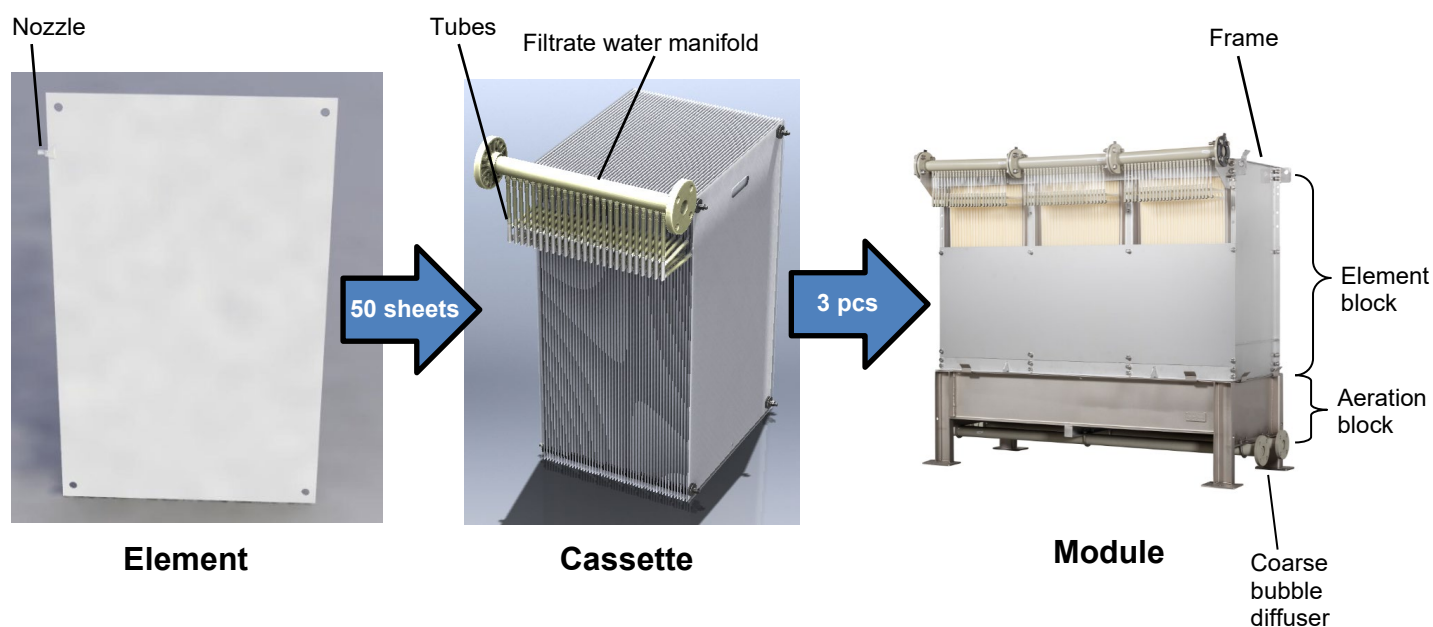

Fig. I-3 Components and Appearance of “NHPA150-1C”

(1) Shape of Element

The membrane element is a flat sheet type as shown in Fig.I-4. At the normal filtration operation, the sludge accumulated on the membrane surface is cleaned up effectively with upward water stream generated with the scouring air supplied from the air diffusers installed at the bottom side (Fig.I-5). This mechanism ensures the stable filtration since the membrane does not easily admit of sludge adherence to its surface.

In addition, thin membrane element which consists of two membrane sheets and spacers in between makes it possible to have higher membrane packing density in the module similar to that of a hollow fiber membrane, and also the vibration of elements by scouring air improves membrane cleaning efficiency.

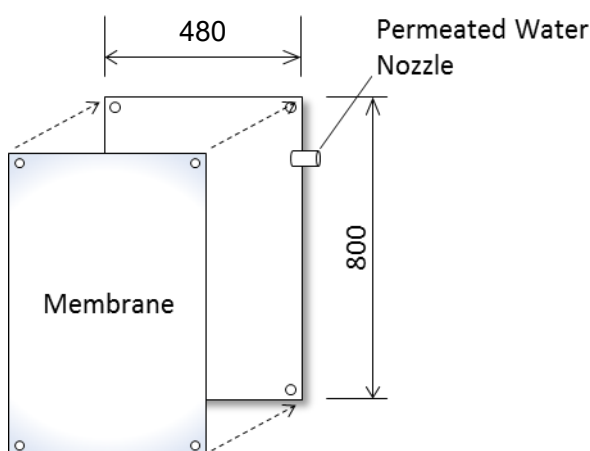

Fig. I-4 Structure of Element

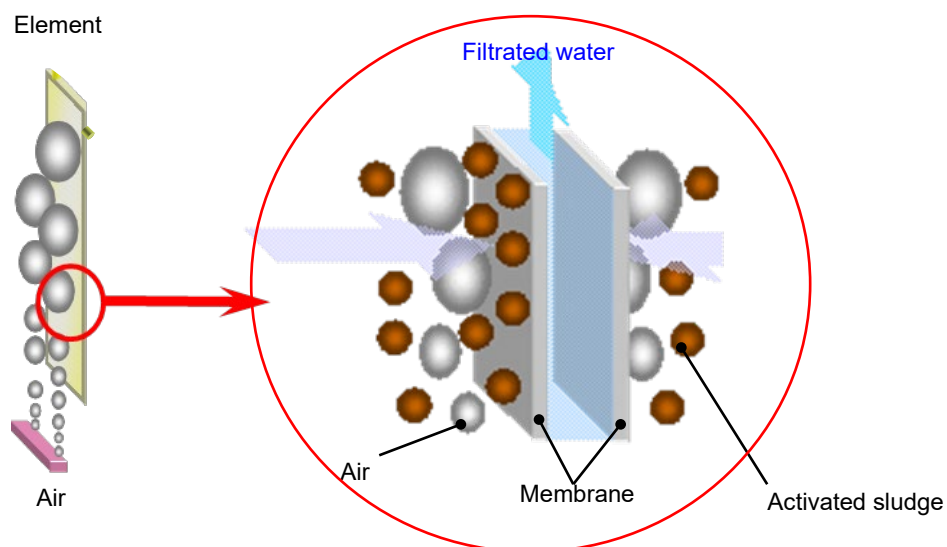

Fig. I-5 Filtration Principle of Activated Sludge

(2) Membrane Structure

The flat sheet membrane consists of a PVDF (Polyvinylidene Fluoride) functional layer and a base layer of PET (polyester) non-woven fabric. This structure gives the membrane superior physical strength and high chemical resistance.

(3) Membrane Pore Size

Numerous small-size pores are distributed evenly over the membrane surface with a sharp pore-size distribution. This structure gives an outstanding high treated water quality and excellent water permeability, making the membrane highly resistant to clogging (see Fig.I-6 and Fig.I-7) compared to other membranes: average pore size is 0.08 micrometer.

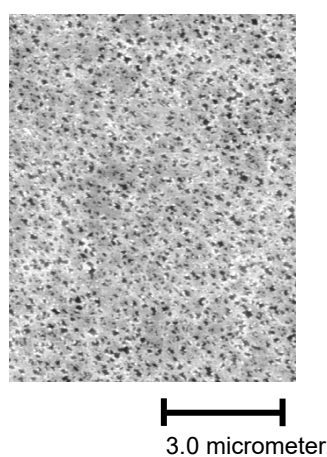

Fig. I-6 Membrane Surface
(photo)

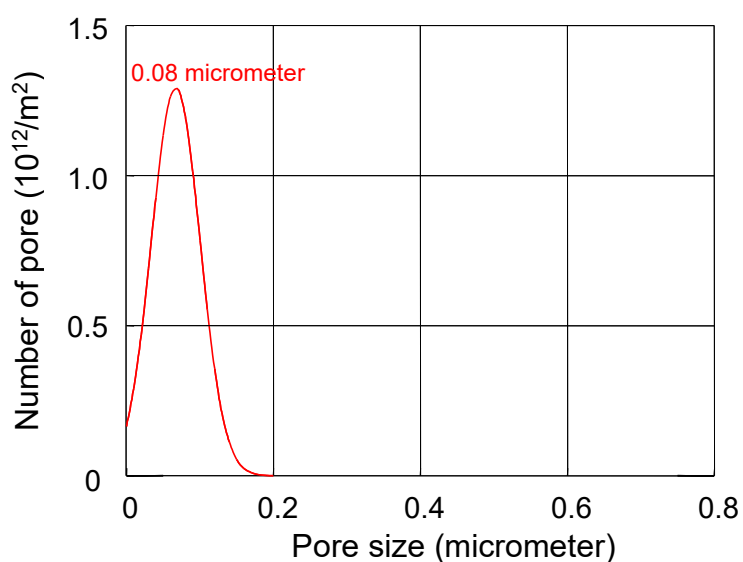

Fig. I-7 Pore Size Distribution

(4) Cassette Replacement

Membranes can be taken out and exchanged by cassette. It is possible to replace only a cassette which contains a damaged membrane.

II. FOR SAFE OPERATION OF “NHPA SERIES”

Before using “NHPA Series”, please thoroughly read this Instruction Manual and follow the instructions described in this manual, especially the safety precautions shown below. The details of each precaution are described in the relevant chapter

1. Safety Instruction for Unpacking and Installation



Prohibited

Attach chains or slings to the lifting lugs when lifting element-deck, an element block or aeration block of “NHPA Series”. Slowly raise the module straight up. Avoid sudden changes in movement to minimize shaking the module. Never allow personnel to stand under the “NHPA Series” during lifting.



Prohibited

Never lift or operate the module with worn or damaged parts. Use chains or slings rated for the weight being lifted. Check the condition of each part before lifting.



Prohibited

Do not lift upper element block and lower element block at once as one unit when lifting NHPA150-3C or 4C. Lift the upper and lower element block separately.



Prohibited

Make provisions, in advance, to access the upper portions of the membrane module via a scaffold or ladder when installing “NHPA Series” module. Do not climb on the module structure. Never step on the air diffuser and filtrate water manifold. Use protective equipment to ensure the safety of workers.



Instruction

Wear the appropriate personal protective equipment (e.g. safety gloves) in order not to cut one’s hand on the edge of the module frame.



Prohibited

During transportation, storage, and installation, take appropriate measures to protect “NHPA Series” or associated components from damage. Do not put any heavy objects directly on the module. Store the module in an area that will minimize the risk of damage from moving equipment like forklifts etc.



Prohibited

Exposing the “NHPA Series” and membrane elements to temperatures above 40 deg C or direct sunlight should be avoided. Exposure to direct sunlight/UV radiation will cause the polypropylene air diffuser and filtrate water manifold to deteriorate.



Prohibited

Take adequate measures, during the installation process, to protect the "NHPA Series" from: sparks emitted from welding equipment, fusion cutting, or grinding.



Prohibited

Protect "NHPA Series" from freezing at all the time.



Prohibited

Avoid pressurizing the filtrate side of "NHPA Series".



Instruction

Install the screen with openings of 3.0 mm or under before the membrane tank. Mesh type screen is recommended. Overflow or waste carryover must be avoided at all the time.



Instruction

Connect the flanges of air diffuser and filtrate water manifold to the piping with the tightening torque of 20 N.m, in order to avoid distortion, leakage, or breakage of the air diffuser and filtrate water manifold.



Instruction

Consider piping materials and regulate the load to the flange connection points at less than 20 kg per flange in order to avoid distortion, leakage, or breakage of the air diffuser and filtrate water manifold. If the load exceeds the limit shown above, put some supports on the piping to reduce the load.

2. Safety Instruction for Operation and Maintenance

**WARNING**

Prohibited

Filtrated water is not for potable uses. Do not drink the MBR filtrate.



Instruction

Before discharging the treated water to the environment or reusing it, make sure to analyze its quality and confirm that the water quality meets the intended purpose.



Prohibited

Do not burn the membranes without appropriate facilities since harmful Hydrogen fluoride (HF) gas will be generated. Hire a professional solid waste disposal company to perform the task when disposing of the membrane elements.

CAUTION

Instruction

Make certain the air discharge valve is in the open position to assure any accumulated air is released when first filling the membrane tank with clean water or sludge. After the tank is filled with clean water, close the air discharge valve.



Prohibited

Do not use ground water for the initial filling of the membrane tank. Ground water may contain considerable concentrations of iron, manganese, calcium, or silica. Naturally occurring compounds of these elements can clog the membrane pores.



Prohibited

White foaming may occur in the membrane tank during clean water operation. The foaming is caused by the leaching of residual biodegradable hydrophilic components contained in the membrane after the manufacturing process. Foaming is normal and does not adversely affect the membrane filtration process but if you want to remove this, do not use silicone-based anti-foaming agent which may cause choking of membrane pores.



Prohibited

Do not operate the membranes longer than necessary to purge the system of entrained air when using clean water in the MBR tank. Prolonged clean water operation can clog the membrane pores.



Prohibited

Keep the membranes wet once they get wet. If the membranes are allowed to dry out, the permeability of the membranes may be permanently reduced.



Instruction

Be sure to pass the seeding sludge through a screen to remove large foreign materials when feeding the seeding sludge. It is recommended that the screen mesh be 3 mm or smaller.



Instruction

Make certain sufficient air is being supplied to the membrane module air diffuser before operating in the filtration mode. Failure to do so will result in the membrane becoming clogged.



Prohibited

Do not allow chemicals, toxic agents, oils, or any other substances into the MBR tank that may adversely affect the condition of the activated sludge.



Prohibited

If anti-foaming agents are to be added to the membrane tank, use only alcohol based anti-foaming products. Do not use silicone-based anti-foaming agent which may cause choking of membrane pores.



Instruction

Avoid abrupt changes to especially pH, temperature, and suction pressure, when operating in the filtration mode, even if these changes are within acceptable operating guidelines.



Instruction

When it is obvious that a module part is worn and potential for failure is high, promptly replace that part with approved replacement parts.



Prohibited

Never expose the “NHPA Series” to freezing temperatures at any time.



Prohibited

Take measures to keep the membrane elements wet when removing the “NHPA Series” module from the activated sludge for inspection or maintenance. Allowing the membrane elements to dry out will adversely affect the membrane’s permeability.

The air scour should be stopped when the filtration process is suspended. There are two exceptions:



Instruction

- 1) Do not stop the air scour during the normal relaxation period.
- 2) Do not stop the air scour if the activated sludge requires air for normal metabolic processes. However, under these conditions the amount of air flow directed to the diffuser should be reduced to just the amount required to maintain sludge viability.



Prohibited

Once a filtrate tube has been removed or disconnected from either the element nozzle or filtrate manifold, it should be replaced with a Toray approved replacement part. Old filtrate tubes lose their elasticity, and the integrity of the seal can be compromised.



Prohibited

Never use a pressure washer machine when washing the membrane module and element which can cause fatal delamination of membrane element edge.

3. Safety Instruction for Chemical Cleaning of Element

**WARNING**

Instruction

Chemical agents used for chemical cleaning can be harmful to one’s health. Wear protective goggles, protective gloves, and other safety gear when handling chemicals. Make sure to check the details of its material safety data sheet (SDS) beforehand.



Instruction

If chemicals come in contact with your skin or clothes, immediately wash the contacted area with a large volume of running water.



Instruction

If chemicals splash into your eyes, immediately flush with large volumes of running water and contact a doctor.



Instruction

Immediately stop the chemical cleaning operation if any of the associated cleaning equipment appears to be malfunctioning.



Prohibited

Do not inject any chemical into the membrane directly from the chemical pump discharge. Excessive membrane element internal pressure will damage the element. Be sure to inject chemicals at a pressure less than 10 kPa (100 mbar).



Instruction

Before starting injecting chemical to elements, confirm that the membrane tank liquid level is more than 500 mm above the top of the module.



Instruction

Store chemicals in a dark, cold place free from direct sunlight.



Instruction

Use chemical storage tanks constructed of chemically compatible materials to prevent corrosion.



Prohibited

Never mix sodium hypochlorite with heavy metals or acids. The resulting chemical reaction will generate toxic chlorine gas.

**CAUTION**

Prohibited

To avoid scattering of chemical solution turn off the air scour during a chemical cleaning.

III. SPECIFICATIONS AND PERFORMANCE OF “NHPA SERIES”

1. Specifications of Element

Table III-1 and Fig. III-1 show the specifications and the physical dimensions for the NHPA Series element.

Table III-1 Specifications of Element (TSP-50080)

Model name	TSP-50080	
Membrane configuration	Flat sheet	
Application	Filtration of activated sludge	
Filtration method	Suction filtration	
Nominal pore diameter (μm)	0.08	
Effective membrane area (m^2)	0.7	
Dimensions (mm)	Total width	480
	Total height	800
	Thickness	1.8
Weight (kg)	Dry	0.25
	Wet (Reference)	0.5
Main material	Membrane	PVDF and PET non-woven fiber
	Nozzle	PE

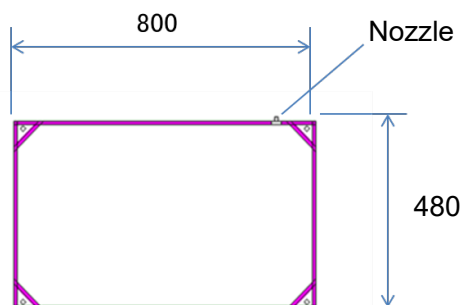

Fig. III-1 Element Appearance (mm)

2. Specifications of Filtrate Tube Assembly

Table III-2 and Fig. III-2 show the specifications and appearance of Tube Assembly.

Table III-2 Specifications of Filtrate Tube Assembly

Material	Thermoplastic polyether-polyurethane (tube) Polypropylene (connector)
Tube Inside diameter (mm)	8
Tube outside diameter (mm)	10
Dimensions (mm)	Approx. 125 x 155



Fig. III-2 Tube Assembly Appearance

**Two elements are connected to one manifold nozzle via tubes and connector*

3. Specifications and Performance of “NHPA Series” Module

Figure III-3 shows the cassette arrangement of “NHPA Series” modules shown in this Instruction Manual. Table III-3a shows the specifications of NHPA050-1C, 100-1C and 150-1C cassette and modules. Table III-3b shows the specifications of NHPA-150-2C, -3C, and -4C cassette and modules.

Note that NHP210-300S and -600D are described in the separate Instruction Manual. Contact Toray in case of replacing existing Toray MBR “TMR Series” or “NHP210 Series” with “NHPA Series”.

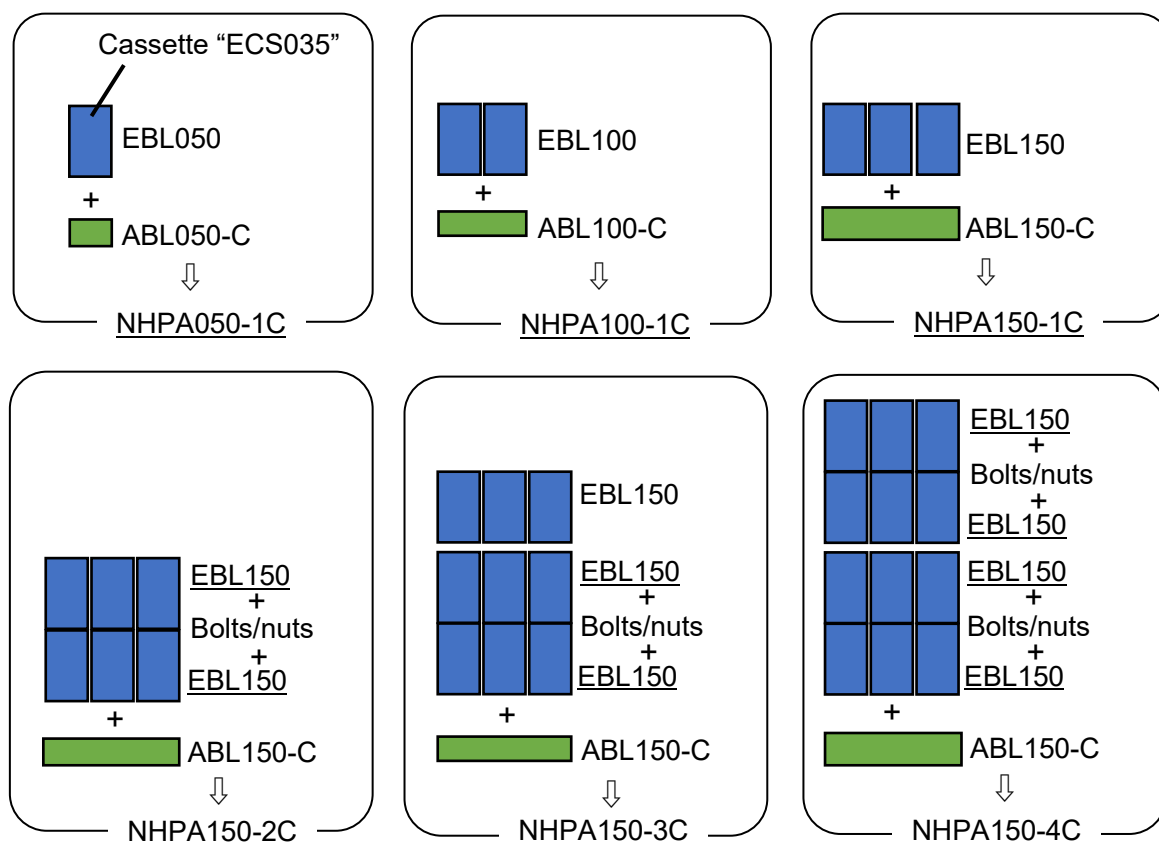

Fig. III-3 Cassette Arrangement of the NHPA Modules Shown in This Manual

Table III-3a Specifications of Cassette and Module (NHPA050-1C, 100-1C and 150-1C)

Model name		ECS035 (Cassette)	NHPA050-1C	NHPA100-1C	NHPA150-1C
Number of membrane elements		50	50	100	150
Cassette structure		-	1 cassette x 1 deck	2 cassettes x 1 deck	3 cassettes x 1 deck
Appearance					
Overall dimensions (mm)	Width	485 (excluding nozzle&hose)	738	738	763
	Length	440	660	1,130	1,617
	Height	820	1,404	1,404	1,404
Dimensions excluding filtrate header pipes and air diffuser pipe (mm)	Width	-	565	565	565
	Length	-	501	986	1,460
	Height	-	1,320	1,320	1,320
Weight (kg)	Module (dry)	N/A	70	110	170
	Aeration block (dry)	N/A	20	30	55
	Cassette/Element block (dry)	17	50	80	115
	Cassette/Element block (sludge clogging) ^{*1}	145	175	340	500
Material	Frame	-	304SS (316LSS is available as option)		
	Filtrate water manifold	Polypropylene			
	Air diffuser	-	304SS (316LSS is available as option)		Polypropylene
Connection	Manifold	ANSI 1 1/2 inch flange using M12 bolts/nuts One flange per module			
	Air diffuser	-	ANSI 1 1/4 inch flange Using M12 bolts/nuts Two flanges per Aeration block		ANSI 1 1/2 inch flange Using M12 bolts/nuts Two flanges per Aeration block.
Operating range ^{*3}	Temperature	5-40 deg C			
	pH ^{*2} of liquid	5-10			
	MLSS	Not higher than 18,000 mg/L			
	Trans-membrane pressure	Not higher than 20 kPa (200 mbar)			
	Cleaning chemicals feed pressure	Not higher than 10 kPa (100 mbar)			
	Cleaning chemicals and chemicals concentration	Sodium hypochlorite (effective chlorine concentration) : 2,000-6,000 mg/L(10<pH<12) Oxalic acid : 0.5-1.0wt% Citric acid : 1.0-3.0wt%			
	Scouring Air Flow rate (NL/min/Module) ^{*4}	- ^{*5}	330 - 670	670 - 1,340	1,000 - 2,000
Scouring Air Flow rate (Cubic feet/min/Module) ^{*4}	- ^{*5}	12 - 24	24 - 48	35 - 71	

*1 The weight assumed in the case of sludge clogging between elements.





*2 Except when the chemical cleaning with the designated chemical agents.

***3 For the standard operating condition refer to the Instruction Manual.**

*4 Air volume as being 0 deg C and 101.325 kPa (1 atm).

*5 MBR operation only by Cassette is not assumed.

Table III-3b Specifications of Cassette and Module (NHPA150-2C, 3C and 4C)

Model name		ECS035 (Cassette)	NHPA150-2C	NHPA150-3C	NHPA150-4C
Number of membrane elements		50	300	450	600
Cassette structure		-	3 cassettes x 2 decks	3 cassettes x 3 decks	3 cassettes x 4 decks
Appearance					
Overall dimensions (mm)	Width	485 (excluding nozzle&hose)	763	763	763
	Length	440	1,617	1,617	1,617
	Height	820	2,304 ^{*6}	3,204	4,104 ^{*6}
Dimensions excluding filtrate header pipes and air diffuser pipe (mm)	Width	-	565	565	565
	Length	-	1,460	1,460	1,460
	Height	-	2,220	3,120	4,020
Weight (kg)	Module (dry)	N/A	285	400	515
	Aeration block (dry)	N/A	55	55	55
	Cassette/Element block (dry)	17	230	345	460
	Cassette/Element block (sludge clogging) ^{*1}	145	1,000	1,500	2,000
Material	Frame	-	304SS (316LSS is available as option)		
	Filtrate water manifold	Polypropylene			
	Air diffuser	-	Polypropylene		
Connection	Manifold	ANSI 1 1/2 inch flange using M12 bolts/nuts One flange per each deck (2C: 2 pcs per module, 3C: 3 pcs per module, 4C: 4 pcs per module)			
	Air diffuser	-	ANSI 1 1/2 inch flange Using M12 bolts/nuts Two flanges per Aeration block.		
Operating range ^{*3}	Temperature	5-40 deg C			
	pH ^{*2} of liquid	5-10			
	MLSS	Not higher than 18,000 mg/L			
	Trans-membrane pressure	Not higher than 20 kPa (200 mbar)			
	Cleaning chemicals feed pressure	Not higher than 10 kPa (100 mbar)			
	Cleaning chemicals and chemicals concentration	Sodium hypochlorite (effective chlorine concentration) : 2,000-6,000 mg/L(10<pH<12) Oxalic acid : 0.5-1.0wt% Citric acid : 1.0-3.0wt%			
	Scouring Air Flow rate (NL/min/Module) ^{*4}	- ^{*5}	1,000 - 2,000	1,300 - 2,000	1,300 - 2,000
Scouring Air Flow rate (Cubic feet/min/Module) ^{*4}	- ^{*5}	35 - 71	46 - 71	46 - 71	

*1 The weight assumed in the case of sludge clogging between elements.

*2 Except when the chemical cleaning with the designated chemical agents.

*3 **For the standard operating condition refer to the Instruction Manual.**

*4 Air volume as being 0 deg C and 101.325 kPa (1 atm).

*5 MBR operation only by Cassette is not assumed.

*6 Check tank height and piping condition when using this module for replacement of existing Toray MBR TMR140-100S or NHP210-300S/600D since NHPA is a little taller than existing modules.

Table III-4 and III-5 shows the performance of "NHPA Series" modules.

Table III-4 Filtrate water quality (Reference value)

Model name		All models
Filtrate water quality ^{*1}	TSS (mg/L) ^{*2}	Not higher than 3.0
	Turbidity (NTU) ^{*3}	Not higher than 1.0

- *1 This value can be attained when operated under the standard operating conditions as specified in this Instruction Manual and Operation and Maintenance guideline during a period specified separately by Toray.
- *2 Measuring method of TSS is complied with Standard Method of Examination of Water and Wastewater 20th Edition (1998), Section 2540D, Total Suspended Solids Dried at 103-105 deg C or ISO 11923.
- *3 Measuring method of NTU is complied with Standard Method of Examination of Water and Wastewater 20th Edition (1998), Section 2130, Turbidity or ISO 7027.

Table III-5 Flow capacity (Reference value)

Model name		NHPA050-1C	NHPA100-1C	NHPA150-1C
Filtration Flow (m ³ /d) ^{*4}	Sewage	3-25	7-50	10-75
	Industrial wastewater	3-17	7-33	10-50

Model name		NHPA150-2C	NHPA150-3C	NHPA150-4C
Filtration Flow (m ³ /d) ^{*4}	Sewage	20 - 150	30-225	40 - 300
	Industrial wastewater	20 - 100	30-150	40 - 200

- *4 This value is just a reference value and not a guaranteed value of Toray. Sustainable operating filtration flow capacity varies among the plant depending on the type of wastewater, total process design, and operating condition. In case of industrial wastewater application, it is strongly recommended to conduct a pilot test before membrane tank designing.

IV. MEMBRANE FILTRATION PROCESS DESIGN FOR “NHPA SERIES”

This section will address the following for the Toray “NHPA Series”: Standard sequence of operation/time chart, illustrated piping, flow schema, and module(s) layout in the membrane tank.

1. Standard Time Chart

Usually intermittent filtration (filtration with relaxation) is recommended. **The most common mode of filtration operation is nine (9) minutes of filtration followed by one (1) minute of suspended membrane filtration (membrane relaxation) with continued air scour**, as shown in Fig.IV-1. This period of relaxation, with no filtration, allows the continued air scour to be more effective at removing solids that may have accumulated on the surface of the membrane. Intermittent filtration followed by a relaxation period is recommended for stable and efficient membrane filtration.

The air scour should be suspended when the filtration process is stopped except for the following conditions:

- 1) During normal membrane relaxation periods.
- 2) During suspended filtration operation unless aeration is required for mixing or biological demand requirements. For the latter the air flow should be reduced to minimum flow rates to prevent membrane damage.

* During low wastewater supply period, basically all modules should be in operation at lower flux rate, considering maintaining viable activated sludge. In case operation of some or all modules will be shut down, the air scour for those modules should be suspended or applied intermittently following the above description. For long-term shutdown, refer to the following Section 9, chapter VIII “Storage Products after Use”.

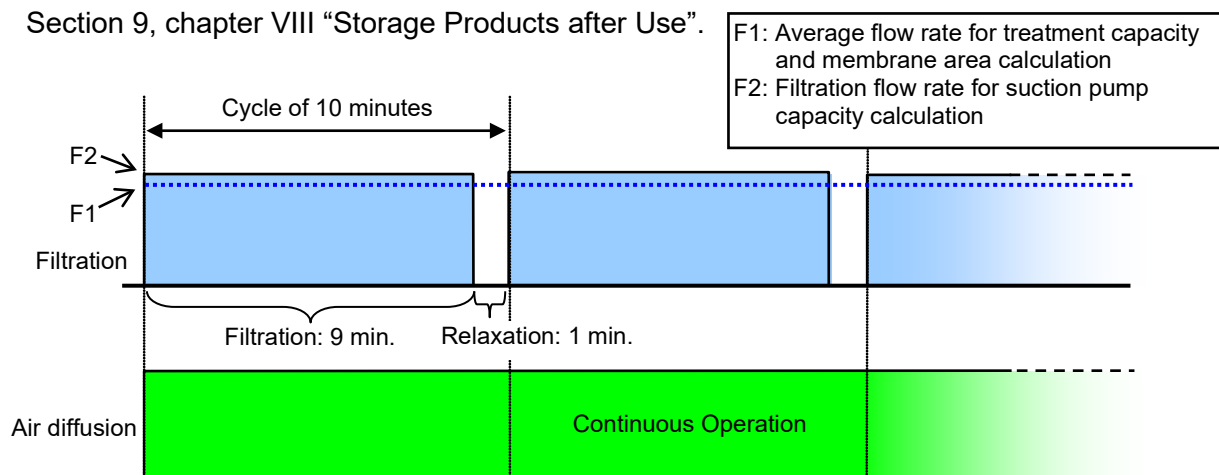

Fig.IV-1 Recommended Time Chart for Intermittent Filtration

2. Flow Diagram of Membrane Filtration

Two (2) flow diagrams of the membrane filtration process are shown below. One is for gravity filtration (when site conditions permit) and the other using a suction pump. Also depicted are major ancillary devices required for the membrane filtration process.

To reduce the risk of membrane clogging, all activated sludge should pass through a fine mesh screen having openings of 3 mm or less prior to being introduced into the membrane tank. Failure to incorporate the screen device may result in large solids clogging or causing physical damage to the membrane surfaces.

In order to equalize BOD load and filtration flow capacity, it is recommended that a buffer/equalization tank be installed to help stabilize operation of the biological treatment and membrane filtration process.

(1) Gravity Filtration Configuration

The filtration process can be accomplished by using elevation differences between the liquid level of the membrane tank and the level of the filtrate outlet (see Fig. IV-2).

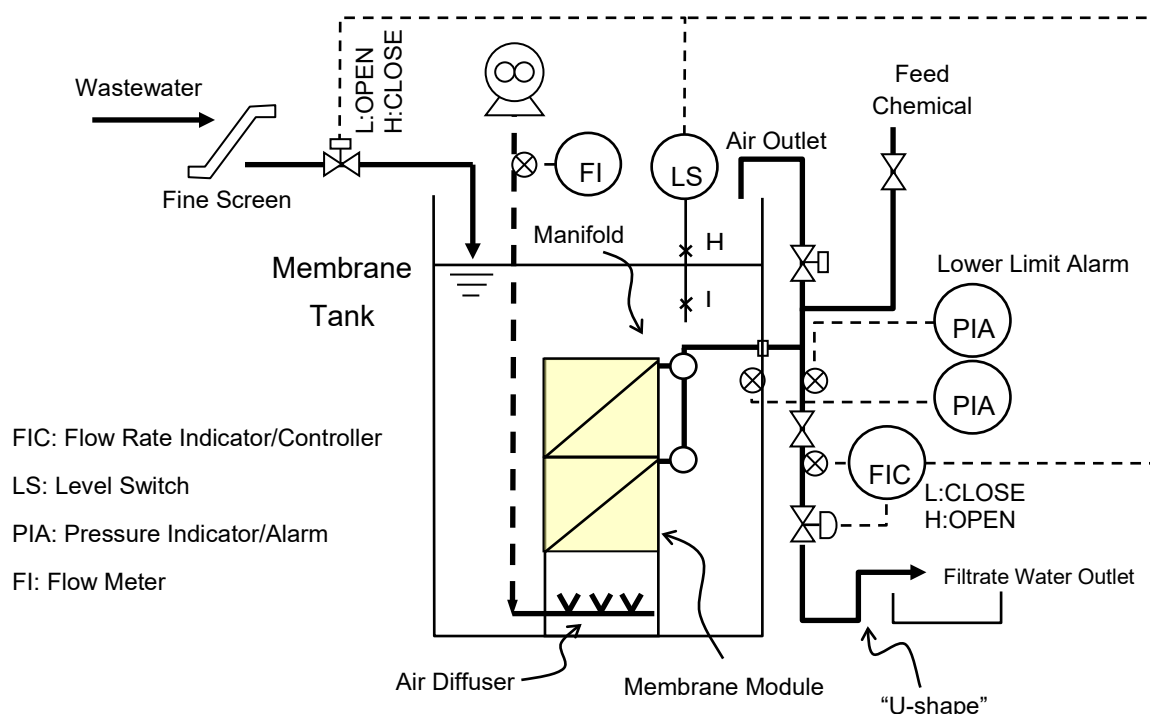

Fig. IV-2 Schematic Flow Diagram for Gravity Filtration (in the case of NHPA150-2C)

In order to obtain enough suction pressure for the filtration process, consider friction loss of all pipes and valves. In addition, the filtrate water outlet should be located at least 3 m below the surface of membrane tank water level.

It is recommended that the piping from the filtrate water manifold to the filtrate water outlet should directly penetrate the tank wall, as shown in Fig.IV-2. In addition, if the filtrate water outlet is an open air discharge, it is recommended that a U-shaped “trap” be constructed to seal the filtrate piping with water.

The filtrate water flow rate is controlled with the automatic control valve (filtrate control valve). When the liquid level of the membrane tank gets to the designed lower limit, the filtrate control valve fully closes to effectively stop the filtration process. When the liquid level of the membrane tank reaches the designed upper limit, the automatic shut-off valve on the raw water influent line closes to stop the raw water flow to the membrane tank.

In the gravity filtration mode, air may accumulate in the filtrate water lines. **To prevent reduction or loss of suction, the air in the filtrate line should be periodically purged to atmosphere at least once per day.** The air purge nozzle should be installed at the highest position of the filtrate water line. The line should also be fitted with an automatic shut-off valve (the air purge valve) just upstream of the air purge nozzle (As shown in Fig.IV-2). The filtration process should be suspended for a few minutes while purging any entrained air from the filtrate line. Close the filtrate control valve and open the air purge valve. After all air has been purged, return the air purge valve to the closed position and open the filtrate control valve.

(2) Pump Suction Configuration

Fig. IV-3 illustrates the general configuration for pump suction filtration.

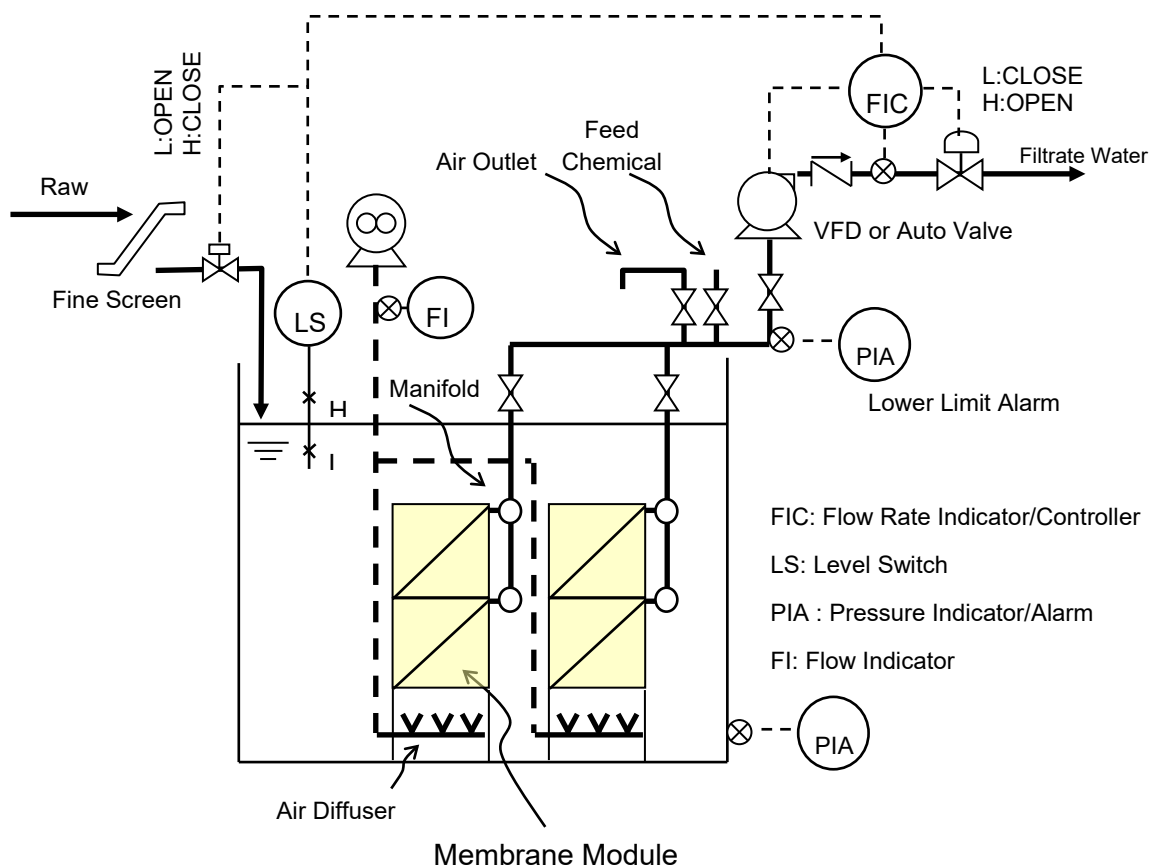

**Fig.IV-3 Schematic Flow Diagram for Pump Suction Operation
(In the case of NHPA150-2C)**

When incorporating a suction pump to facilitate water flow through the membrane, the filtrate water flow rate should be controlled using a flow meter fitted with control output signals and a suction pump fitted with a VFD device or an automatic control valve. In the event the membrane tank water level reaches the designed lower limit, the filtration mode should be stopped. As with the gravity filtration mode previously discussed, should the membrane tank water level reach the designed upper limit, the upper limit controller will close the raw water inlet control valve.

Since the liquid in the tank contains a significant amount of dissolved air, some of that dissolved air will accumulate in the filtrate pump suction line. **It would be necessary to periodically purge the filtrate line of any accumulated air and in this context, it is quite beneficial to locate the pump at the top of filtrate piping.** A range of methods can be used to remove air from the filtrate line: vacuum pump, ejector, or manual water injection. Contact Toray or refer to the engineering manual for the additional details.

(3) Required ancillary devices for membrane filtration process are listed below. In some instances, additional components may be required.

a. Fine screen

Incoming wastewater to the membrane tank should pass through a screen having 3.0 mm or less openings. Failure to incorporate a screening device will result in clogging or permeant damage to the membrane. Mesh type screens are recommended. Overflow or waste carryover into the submerge membrane tank must be avoided at all times.

b. Flow control device

A flow rate controller, a flow meter combined with an automatic control valve, or a flow meter combined with VFD controlled suction pump should be installed on the filtrate water line to control the flow rate of filtrate water. It is recommended that each train be fitted with its own discreet filtrate flow rate controller when operating more than one “NHPA Series” module simultaneously.

c. Trans-membrane pressure (TMP) measurement & calculation

For trans-membrane pressure (TMP) determination, the differential pressure (in the filtrate line and water level) needs to be measured and calculated. This can be accomplished by either installing two pressure sensors and calculating the difference in the readings in the PLC or using a differential pressure gauge.

When using two pressure gauges, one pressure gauge should be installed on the filtrate water line and the other on the membrane tank, to monitor the trans-membrane pressure. When operating several “NHPA Series” modules simultaneously in one train, it is advised installing one differential pressure measuring instrument for each train.

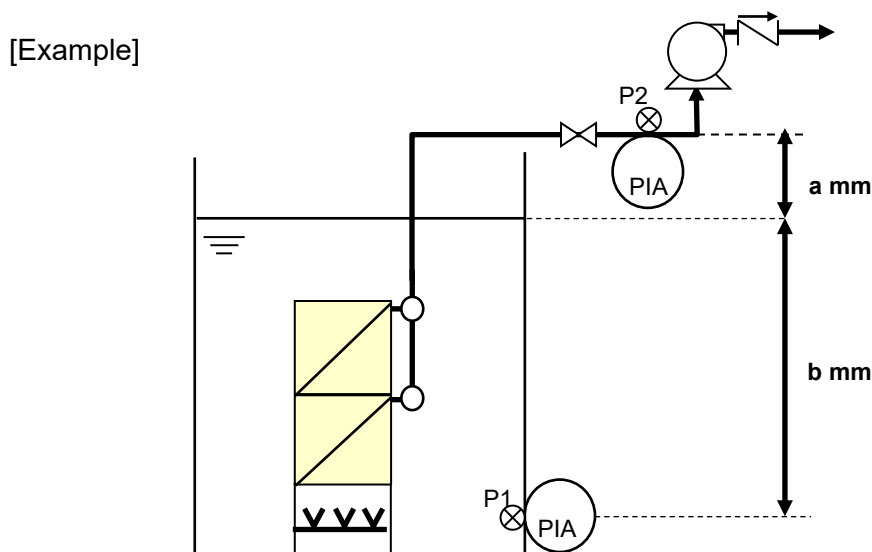

Fig.IV-4 Trans-Membrane Pressure Measurement & Calculation

- a = 1,000 mm (= 10 kPa, 100 mbar), b = 3,000 mm (= 30 kPa, 300 mbar)
- PIA readings;

	Filtration (pump ON)	Relaxation (pump OFF)
P1 (kPa)	29	30
P2 (kPa)	-15	-10

In this case, TMP is calculated as follows;

$$TMP = (P1_{Filtration} - P1_{Relaxation}) - (P2_{Filtration} - P2_{Relaxation}) = (29) - (30) - [(-15) - (-10)] = 4 \text{ kPa}$$

* In case water level is stable, $P1_{Filtration}$ is equal to $P1_{Relaxation}$. Then TMP is;

$$TMP = P2_{Relaxation} - P2_{Filtration} = -a - P2_{Filtration}$$

d. Air supply unit (such as a blower)

This unit supplies air to the air diffusers of "NHPA Series" module. The air flow rate supplied to the module should be always within the range of "Scouring Air Flow Rate" indicated in Table III-3.

e. Air flow meter.

An air flow meter is recommended to be installed to check the flow rate of the scouring air supplied to the module. In case of operating several "NHPA Series" modules simultaneously in a train, it is advised installing, at a minimum, one air flow meter for each train.

f. Suction pump

A suction pump is required in the case of pump suction configuration. To achieve an accurate designed filtrate flow rate, the suction pump should be fitted with a VFD controller. The use of a volute pump (centrifugal pump) or volumetric pump (screw pump) with self-priming functions is recommended.

g. Level sensor

Level sensors are required to be installed in the membrane tank to monitor and control the liquid level of the membrane tank and to facilitate calculating TMP via the PLC.

h. Siphon breaking device on filtrate piping

When using a suction pump, it may be necessary to have a means to break the filtrate siphon if the filtrate discharge point is lower than water level of the membrane tank. This siphon flow has to be avoided and the filtrate flow has to be stopped whenever the pump stops.



CAUTION

It is required that a screen with openings of 3.0 mm or less be installed prior to the membrane tank. A mesh type screen is recommended. Avoid any overflow or waste carryover at all the times.

3. Layout of “NHPA Series” Modules in Membrane Tank

(1) Layout of Modules in Membrane Tank

Fig.IV-5a shows how the liquid circulates in the membrane tank. An upward flow of liquid is generated as the air is supplied from the air diffuser located at the bottom of the membrane modules. This flow circulates downward along both sides of the element block.

This circulation flow serves to scour the membrane element surfaces and at the same time to mix the activated sludge. **It is very important to arrange the membrane modules with appropriate distances between each module to obtain an effective activated sludge circulation, as well as not having excessive space around the modules which allows sludge sedimentation (installing sludge agitation if necessary).**

Fig.IV-5a and Fig.IV-5b illustrate a side view and a top view of the membrane tank containing three membrane modules. It is required to adhere to the dimensions of W1, W2, W3, and L1 listed below.

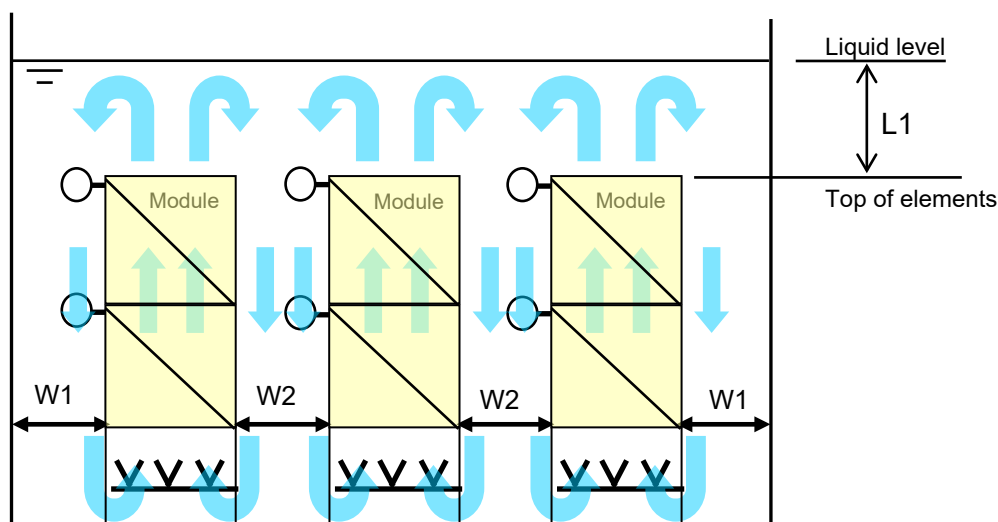

Fig.IV-5a Membrane Module Layout in Membrane Tank (side view)

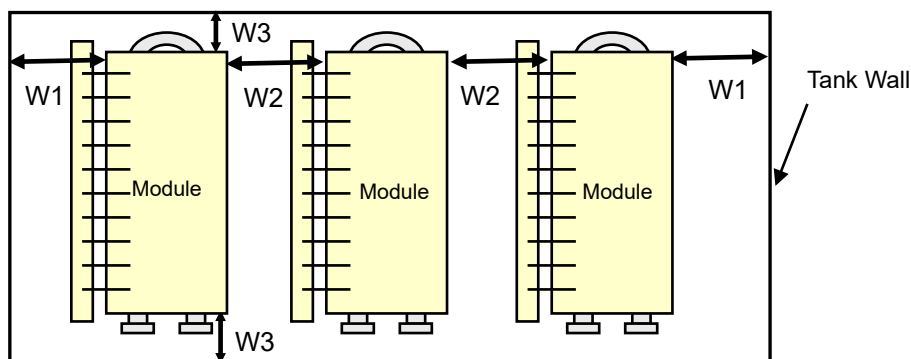

Fig.IV-5b Membrane Module Layout in Membrane Tank (top view)

- (i) W1 : 380 to 680 mm
- (ii) W2 : 430 to 730 mm
- (iii) W3 : W3 should be as short as possible (normally about 400 mm) within the range allowing piping and maintenance work.
- (iv) L1 : L1, the distance between the top of the element and the liquid level of the tank, should be 500 mm or over at any time of the operation.

- * **Refer to the “Dimensions” on the Table III-3a/b for layout design, not “Overall dimensions”.**
- * Contact Toray in the event the recommended layout design is not possible when installing the membrane modules in an existing aeration tank.
- * Contact Toray in the case the existing tank floor is not level, If the existing tank floor is not level, it is recommended that stands be installed as shown in Fig.IV-6.

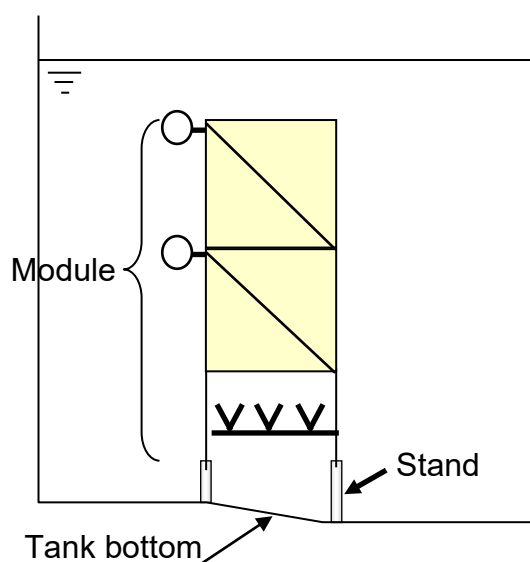

Fig.IV-6 Installation with Stands (side view)

(2) Layout of Modules Installed with Other Aeration Equipment

In the case that the membrane modules are to be installed in a tank with other oxygen-supplying aeration equipment or in an existing tank where there is already other oxygen-supplying aeration equipment, take the following precautions in addition to what is mentioned in the above section.

The membrane modules should be kept at least twice the W3 dimension noted in Fig. IV-7 from any other oxygen-supplying equipment.

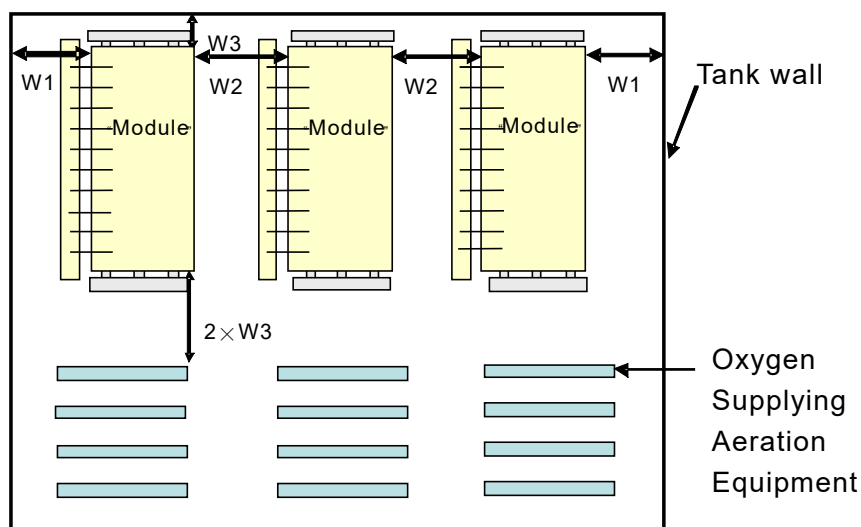

Fig.IV-7 Membrane Module Layout in Membrane Tank with Other Aeration Equipment (top view)

Alternatively keep twice the W1 distance between the modules and other aeration equipment in the case shown in Fig.IV-8.

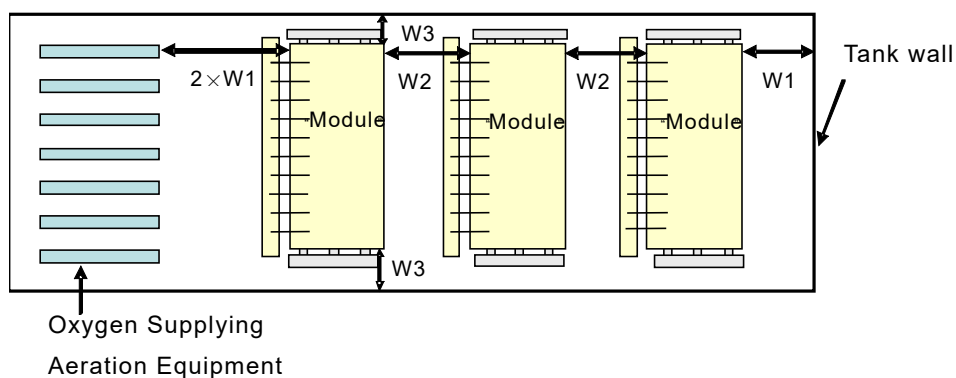

Fig.IV-8 Membrane Module Layout in Membrane Tank with Other Aeration Equipment (top view)

4. Piping

The procedures of the pipe arrangement for the air diffusers and the filtrate water manifold are described in this section. The connections of the air diffuser and the filtrate water manifold are shown in the module drawings attached to this manual.

(1) Pipe Arrangement for the Air Diffusers

The pipe from the air supply device (blower) is connected to the two flanges (A) located on the air diffuser (see Fig.IV-9). When using polypropylene diffuser, heat tolerant plastic pipe and/or use of flexible pipe/joint is recommended for the pipe for easy flange connection without putting stress to the air diffuser. Also, it is recommended that the air supply flange (B) be installed above the tank liquid level to lift the module from the tank if necessary.

To facilitate cleaning of the air diffuser, install branch pipes and valves as illustrated in Fig. IV-9. It is recommended that these valves be located within 500 mm above the liquid surface. It is also highly recommended that these valves be automatically actuated valves with associated PLC control circuits for automatically controlled air diffuser maintenance cleaning. Refer to VIII-2 for the procedure recommended for cleaning the air diffusers.

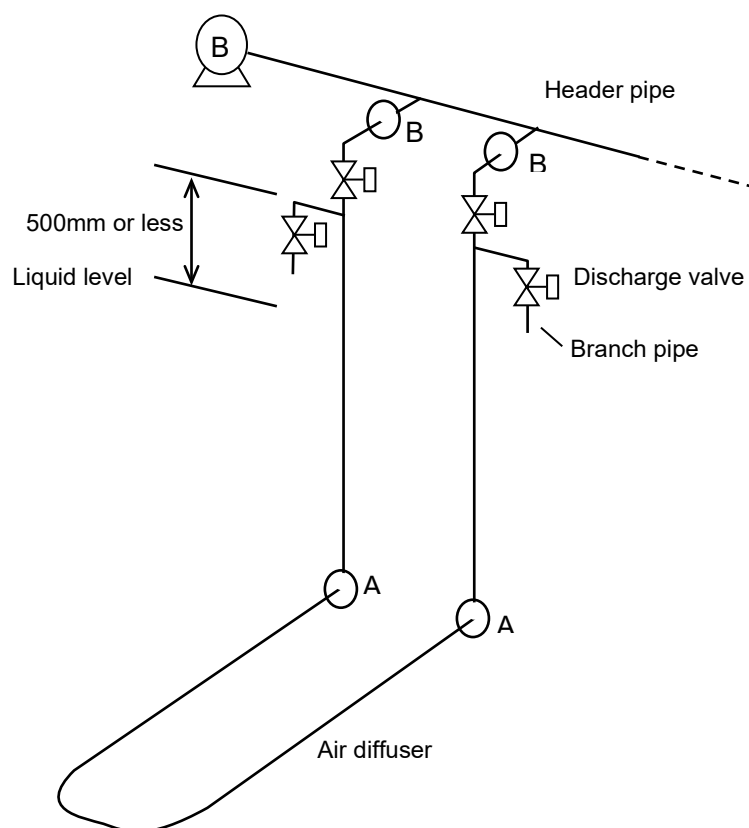

Fig.IV-9 Example of Piping to Air Diffuser



Consider piping materials and regulate the load to the flange connection points at less than 20 kg per flange in order to avoid distortion, leakage, or breakage of the air diffuser and filtrate water manifold. If the load exceeds the limit shown above, put some supports on the piping to reduce the load.

(2) Pipe Arrangement for the Filtrate Water Manifold

Fig.IV-10 and Fig.IV-11 illustrate two approaches of the filtrated water piping from the Membrane Tank. Fig.IV-10 shows downward piping and Fig.IV-11 shows upward piping.

The downward piping is incorporated when sufficient suction can be developed via siphon (the filtrate discharge lower than the tank level). The upward piping is for operation when a suction pump is required (the pump is above the membrane tank).

In both upward and downward piping, the chemical injection valve and the air discharge valve should be installed on a pipe tee between the pipe from the filtrate water manifold to the filtrate water control valve. These devices are necessary for chemical cleaning and are detailed in sections VIII-3 to VIII-6.

It is advised that you prepare and attach a “riser pipe” to connect two filtrate manifolds of two element-decks for ease of piping and handling (out of Toray’s scope of supply). **Fig.IV-12 shows example of the riser pipe. In case of using a riser pipe, the two element-decks have to be stacked and connected so that filtrate manifolds of both decks come to the same side.**

In case of NHPA150-3C and 4C, prepare separate riser pipes for the lower two element-decks and the upper one/two element-deck(s), and do not connect all decks to one single riser pipe. Refer to Fig.IV-13.

It is also advised confirming that the diameter of filtrate piping is suitable for the assumable maximum flow velocity at each point, especially after aggregating filtrate flow from several manifolds such as header pipes.

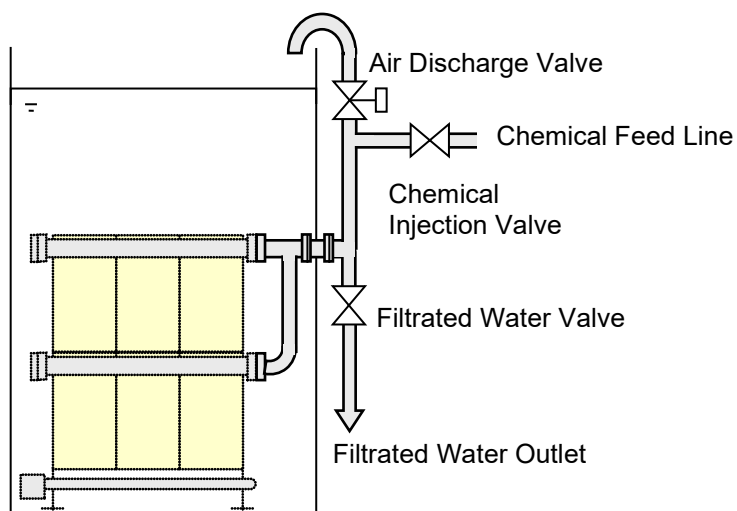

Fig.IV-10 Downward Piping from Membrane Tank

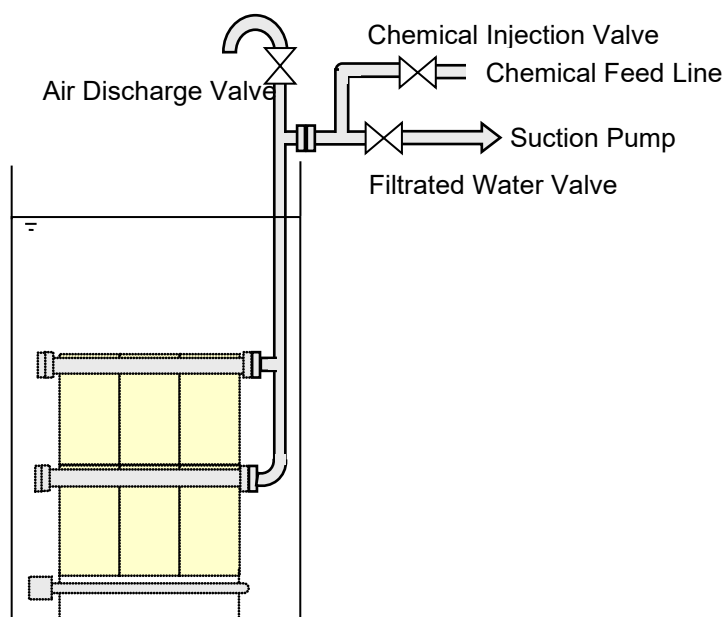

Fig.IV-11 Upward Piping from Membrane Tank



Fig.IV-12 Riser Pipe (example)



Fig.IV-13 Separate Riser Pipe for Upper/Lower Decks (example)



CAUTION

Consider piping materials and regulate the load to the flange connection points at less than 20 kg per flange in order to avoid distortion, leakage, or breakage of the air diffuser and filtrate water manifold. If the load exceeds the limit shown above, put some supports on the piping to reduce the load.



CAUTION

Be sure to confirm that the diameter of filtrate piping is suitable for the assumable maximum flow velocity at each point, especially after aggregating filtrate flow from several manifolds such as header pipes.

(3) Maximum Number of Modules in a Single Header

A maximum number of 30 modules per filtrate header with subgroups of max 10 modules for aeration (diffuser cleaning) and chemical cleaning is possible to design.

V. INSTALLATION OF “NHPA SERIES”

1. Preparatory Procedure

- (1) Take precautions to plan the route for the “NHPA Series” to the membrane tank. The route should include the unloading area for the “NHPA Series” to the final installation site.
- (2) Make arrangements of the necessary equipment to unload the “NHPA Series” from a truck such as a forklift or pallet jack etc.
- (3) **Prior to installation, confirm that all necessary piping components are in place within the membrane tank. Make certain that all construction waste materials have been removed from the tank.** All loose materials remaining in the tank should be removed from the tank prior to installation of the “NHPA Series”. **In addition, it is important to test all water and air lines to confirm that all field assembled joints are free of leaks.**

2. Unloading/Lifting Products

Unload "NHPA Series" with suitable equipment such as forklift, crane, or truck mounted hydraulic lift gate.

Inspect the "NHPA Series" module for any damage inflicted during transport.

- (1) You will receive two packages with the “NHPA Series” module. One is the element block complete with the prescribed number of membrane elements and the other box an aeration block.
- (2) Do not lift the packages from overhead when unloading the package which contains multiple element blocks or aeration blocks. Always lift these packages from underneath using a forklift or pallet jack.
- (3) To avoid damage, do not stand or sit on the packages.
- (4) A cassette can be handled by manpower only before starting operation. If several cassettes are installed in an element block frame, do not move it by hand and use appropriate equipment such as a forklift.
- (5) Use the lifting brackets on the module to connect to the lifting device when lifting "NHPA Series" (or lifting element block/aeration block separately) after unpacking. Take precautions to keep the “NHPA Series” components upright in their proper orientation.
- (6) **Be careful not to damage element nozzles, air diffusers, filtrate manifolds, or other components when lifting.**
- (7) Employ good safety practices when unloading the “NHPA Series” components.



DANGER

Attach chains or slings to the lifting lugs when lifting “NHPA Series”. Slowly raise the module straight up. Avoid sudden changes in movement to minimize shaking the module. Never allow personnel to stand under the “NHPA Series” during lifting



Never lift or operate the module with worn or damaged parts. Use chains or slings rated for the weight being lifted. Check the condition of each part before lifting.



Prior to lifting, make ready a flat area to set the module down. This will minimize the potential for damage. Damage will occur if the module is allowed to tip over.



Do not apply a strong force to polypropylene air diffuser and filtrate water manifold when moving the module. Otherwise, the air diffuser and filtrate water manifold may get damaged.

3. Checking Products

Upon arrival of the “NHPA Series”, immediately check the following:

- (1) Make certain all items are delivered as stated on the shipping documents.
- (2) Check to make sure no damage was inflicted during transport.
- (3) Check to confirm that the protective covers remain in their correct position.
- (4) Check to confirm that all the filtrate tubes are surely connecting elements and manifold.

4. Storing Products

“NHPA Series” has to be stored indoors under lower than 40 deg C of the temperature. If the “NHPA Series” cannot be stored indoors due to prevailing construction site conditions, try to minimize the time being out of doors. As soon as possible, move the “NHPA Series” into a protected area to avoid accidental damage. Always comply with all recommended storage conditions.

At all times during transportation and installation of the “NHPA Series”, protect the module elements and other components from damage. Take special measures to protect the elements from sparks caused by welding, fusion cutting, or grinding. If any of these activities are in progress, be sure to protect the elements by using fireproof sheets or other protective materials.

- (1) Keep the module upright at all times and do not place any heavy objects on the module.
- (2) Maintain the temperature below 40 deg C.
- (3) Prevent from freezing.
- (4) Prevent from getting wet. Avoid conditions where condensation may occur on the module or elements.
- (5) Do not submerge in water until such time as the “NHP210 Series” is ready for final installation.
- (6) Avoid module exposure to direct sunlight.
- (7) Protect from falling objects. Again, avoid exposure to sparks from grinding or welding.

**CAUTION**

Exposing the “NHPA Series” and membrane elements to temperatures above 40 deg C or direct sunlight should be avoided. Exposure to direct sunlight/UV radiation will cause the polypropylene air diffuser and filtrate water manifold to deteriorate.

**CAUTION**

Protect “NHPA Series” from freezing.

**CAUTION**

Take adequate measures to protect “NHPA Series” from sparks caused during welding, fusion cutting, or grinding.

**CAUTION**

Take precautions to protect the elements from damage. Do not place heavy objects on the module. Protect the module from potential collisions with other moving objects.

**CAUTION**

Be careful not to damage the rubber parts of air diffusers and element fixing brackets.

5. Installing Products

Check the followings before module installation:

- (1) Make sure all necessary work in the membrane tank has been completed.
- (2) Make sure the tank and all pipes have been thoroughly cleaned and free of debris.
- (3) Confirm that there are no leaks in any of the tank and water or air lines.
- (4) Using clean water in the tank, check the operation of major equipment components such as: pumps, blowers, sensors, and control systems.

Review the drawings in the REFERENCE to make certain final tie-ins to the “NHPA Series” are as per the drawings. Refer to the information in the REFERENCE if you intend to install the module without anchoring the module to the floor of the tank (e.g., using guide rails instead).

- (1) Installation of Aeration Blocks (on the bottom of the membrane tank using anchors)

First install the aeration blocks in the membrane tank using suitable anchors. If multiple aeration blocks are to be installed, record each block’s serial number and position within the tank.

The air diffusers should be installed in a horizontal position to achieve uniform scouring aeration. The maximum allowable deviation from the dead level for the air diffusers is 3/1,000 on the top surface of the aeration block in both lateral and vertical directions.

- (2) Plumbing in Air Diffusers

Prior to plumbing in the air diffusers, flush all pipes out. The air diffuser should be connected to the pipe from air supply unit with the flanges. When using a polypropylene diffuser, please

consider piping materials and regulate the load to the flange connection points at less than 20 kg per flange, in order to avoid distortion, leakage, or breakage of the plastic air diffuser. If the load exceeds the limit above, put some supports on the piping to reduce the load.

One air diffuser is shipped from the factory with two rubber gaskets. Connect air diffuser to the air-line using rubber gaskets with the tightening torque of 20 N.m.

After plumbing in the air diffusers, fill the membrane tank with clean water until the aeration blocks are completely submerged in the clean water. Next turn on the air supply, check to make certain that the air is being evenly distributed throughout the aeration block.

(3) Installation of Element Blocks

Adjacent two (2) element-decks can be connected to comprise the element block by bolts and nuts. If you apply riser pipe (see (2) in the page 24), relevant decks must be connected.

Put the element block(s) onto the aeration blocks. Joint both using provided bolts if guide rail system is not applied in case of -1C and -2C.

Use guide rails certainly and do not connect three (3) element-decks or more when installing taller module NHPA150-3C and 4C. For 3C put one (1) upper element-deck onto the lower element block which consists of two (2) bolted element-decks. For 4C put the upper element block which consists of two (2) bolted element-decks onto the lower element block which consists of two (2) bolted element-decks.

Also, do not lift and install entire decks at one time. Upper/lower element block must be installed one by one to avoid distortion or damage to the element block which may cause severe accident.

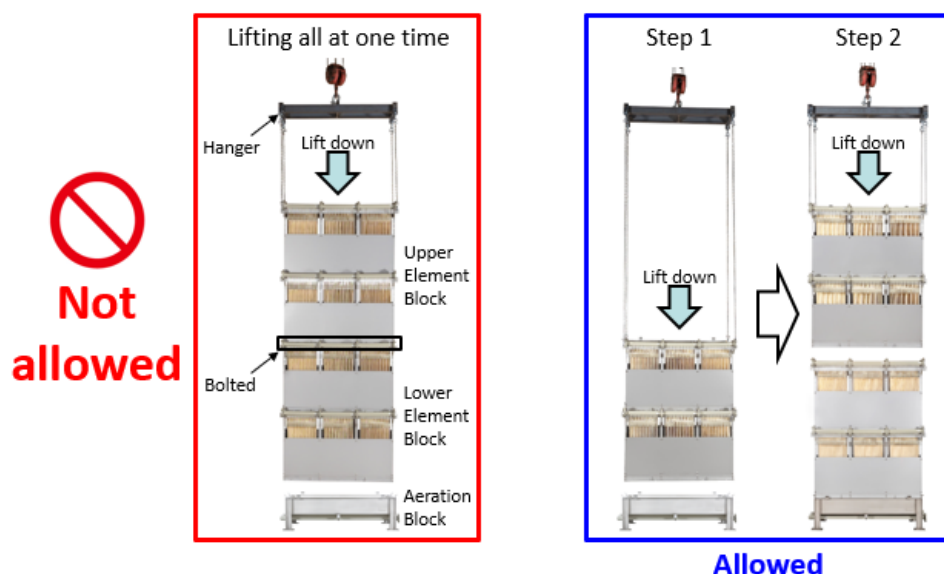

The serial number of each aeration block and its position in the tank should be recorded. After installation, **take adequate measures to protect the elements and other components from damage by covering with fireproof tarps.**

(4) Plumbing in Filtrate Water Manifold

Before making any connections to the filtrate manifolds, the water line should be flushed to remove any residual construction debris and avoid pressurizing the filtrate side of "NHPA Series" over 10 kPa.

Filtrate water manifolds are shipped from the factory with one blind flange furnished at one end only. Connect the filtrate water pipe to the open end flange of the filtrate manifold and confirm tightening of the blank flange since it may have got loose during transport. The buyer may need to purchase a compatible flange for connecting the filtrate water line to the supplied filtrate water manifold. Connect the filtrate water manifold to the filtrate water line using rubber gasket with the tightening torque of 20 N.m.

To avoid membrane element damage, never place the filtrate connections to the membrane elements under stressful forces.

**DANGER**

Attach chains or slings to the lifting lugs when lifting element-deck, element block, or aeration block of "NHPA Series". Slowly raise the module straight up. Avoid sudden changes in movement to minimize shaking the module. Never allow personnel to stand under the "NHPA Series" during lifting.

**DANGER**

Use chains or slings with sufficient load rating to lift the weight of the "NHPA Series" or any of its components.

**DANGER**

When installing "NHPA Series" module, make provisions, in advance, to access the upper portions of the membrane module via a scaffold or ladder. Do not climb on the module structure. Never step on the air diffuser and filtrate water manifold. Use protective equipment to ensure the safety of workers.

**DANGER**

Do not lift upper element block and lower element block at one time when lifting NHPA150-3C or 4C. Disconnect the upper block from the lower block prior to lifting, the upper/lower element blocks should be lifted separately.

**CAUTION**

Wear the appropriate personal protective equipment (e.g. safety gloves) in order not to cut hand on the edge of the module frame.

**CAUTION**

Connect the flanges of air diffuser and filtrate water manifold to the piping with the tightening torque of 20 N.m, in order to avoid distortion, leakage, or breakage of the air diffuser and filtrate water manifold.

**CAUTION**

Consider piping materials and regulate the load to the flange connection points at less than 20 kg per flange in order to avoid distortion, leakage, or breakage of the air diffuser and filtrate water manifold. If the load exceeds the limit shown above, put some supports on the piping to reduce the load.

**CAUTION**

Avoid pressurizing the filtrate side of "NHPA Series" over 10kPa.

VI. START OF OPERATION

1. Clean Water Operation

(1) Check the Following Items Prior to Module(s) Operation:

- a. Check that the air diffusion pipe and the filtrate water pipes are properly connected to the module(s).
- b. Check that the element block is securely installed on the aeration block.
- c. Remove any protective materials covering the membrane tank. Check that the membrane tank is completely free of dust and debris. The presence of soil and dust may cause damage to the module.
- d. **Open the air discharge valve on the filtrate line to release any air from the filtrate side of the elements before introducing clean water into the membrane tank.**
- e. Introduce clean water (tap water or filtered water) to the membrane tank. Fill the tank up to the recommended operating liquid level.
- f. Close the air discharge valve located on the filtrate line, after filling the membrane tank.



CAUTION

Open the air discharge valve before feeding clean water to the membrane tank. Close the air discharge valve after feeding water.



CAUTION

Do not use natural ground water for clean water operation, as it may contain much amount of iron, manganese, calcium, and silica which may cause the clogging of the membrane pore.

(2) Clean Water Operation

After feeding clean water to the membrane tank, follow the recommended procedures below to start the clean water operation.

- a. Start the blower to supply air to the air diffusers. Check that the required amount of air is supplied to the air diffusers and the diffused air is being distributed evenly within each module.
 - * White foaming may occur in the membrane tank during clean water operation. The foaming is caused by the leaching of residual biodegradable hydrophilic components contained in the membrane after the manufacturing process. Foaming is normal and does not adversely affect the membrane filtration process but **if you want to remove this, do not use silicone-based anti-foaming agent which may cause choking of membrane pores.**
- b. Check that the recommended amount of air is evenly supplied to each module when using one blower to supply air for multiple modules. If the distribution of air is found not evenly distributed between modules, it may be necessary to modify the air line header piping inside diameter to achieve uniform air distribution to each module.

- c. Check the system controls and associated control components for proper operation and proper sequence of operation.
- d. Start the clean water filtration process. At the initial operation of suction pump, priming (filling the suction piping with water) may be needed for proper pump suction and in that case avoid pressurizing the filtrate side of "NHPA Series" over 10kPa. Measure and record the trans-membrane pressure and water temperature at designed filtration rates (**at normal, maximum, and minimum flow rates**). It is beneficial to periodically record flow rates and TMP values.
- e. Stop the clean water filtration process and discontinue the air supply as soon as the above tests have been satisfactorily completed.

**CAUTION**

White foaming may occur in the membrane tank during clean water operation. The foaming is caused by the leaching of residual biodegradable hydrophilic components contained in the membrane after the manufacturing process. Foaming is normal and does not adversely affect the membrane filtration process but if you want to remove this, do not use silicone-based anti-foaming agent which may cause choking of membrane pores.

**CAUTION**

Do not conduct clean water operation for a long time. Clean water operation may cause membrane clogging.

**CAUTION**

Keep the membranes wet once they get wet. If the membranes are allowed to dry out, the permeability of the membranes may be permanently reduced.

**CAUTION**

Avoid pressurizing the filtrate side of "NHPA Series" over 10 kPa.

2. Seeding Sludge Injection

Do not attempt to produce filtrate from any wastewater that has not first been seeded with activated sludge. Failure to do so will result in severe clogging of the membrane pores

Follow these steps when seeding sludge in the membrane tank with activated sludge:

- (1) Locate a nearby wastewater treatment facility that treats wastewater similar in composition to the wastewater to be treated with the new "NHPA Series". Make arrangements to transport some of that healthy, activated sludge from the nearby wastewater facility to the facility needing the seeding sludge. Activated sludge with higher MLSS concentration and higher MLVSS/MLSS ratio is preferable. **Initial MLSS concentration of the membrane tank should be at least 3,000 mg/L or higher. Higher than 7,000 mg/L is preferred.**
- (2) **Supply the seeding sludge through the <3mm screen to the tank.**
- (3) Begin feeding the raw wastewater as soon as possible after the activated sludge has been introduced into the membrane tank.
- (4) Do not use seeding agents.

- (5) Do not use silicone-based anti-foaming agent which may cause choking of membrane pores.

**CAUTION**

Prior to introduction of any seeding sludge into the membrane tank pass all sludge through a 3 mm or less mesh screen device.

**CAUTION**

Open the air discharge valve before feeding sludge to the membrane tank. Close the air discharge valve after feeding sludge.

3. Actual Filtration Operation

After successfully seeding the sludge within the membrane tank, start the air supply to the diffusers, start sludge circulation, and activate the filtration process and the raw wastewater feed.

Pay particular attention to the following operational parameters:

- (1) The condition of the seeded activated sludge may not be optimal for membrane filtration until such time as the food to microorganism ratio (F/M) has been optimized. To avoid fouling the membrane elements while the activated sludge is evolving, operate the MBR well below the designed flux rate. This is especially important until the activated sludge MLSS concentration approaches 7,000 mg/L. **Gradually increase the flux rate as the condition of the activated sludge improves.**
- (2) At the initial operation of suction pump, priming (filling the suction piping with water) may be needed for proper pump suction and in that case avoid pressurizing the filtrate side of "NHPA Series" over 10kPa.
- (3) Sludge parameters such as MLSS and sludge filterability (see (11) in the page 41) should be checked frequently to assess the actual sludge condition.
- (4) Check the air diffuser cleaning procedure and associated automated valves for proper operation. Details for the procedure are given in the chapter VIII.
- (5) Once the filtrate water flow has stabilized, measure and record the trans-membrane pressure and the liquid temperature. Details for operation control are given in the next chapter.

**CAUTION**

The air scour should be stopped when the filtration process is suspended. There are two exceptions:

- 1) During the normal relaxation period.
- 2) When the activated sludge requires air for normal metabolic processes. However, under these conditions the amount of air flow directed to the diffuser should be reduced to just the amount required to maintain sludge viability.

**CAUTION**

Avoid pressurizing the filtrate side of "NHPA Series" over 10kPa.

VII. OPERATION CONTROL

1. Standard Operating Conditions

Table VII-1 shows standard operating conditions for “NHPA Series”.

To ensure stable operation, operating parameters such as MLSS, sludge viscosity, DO (dissolved oxygen concentration), and pH should be kept in the range of recommended standard operation conditions listed in Table VII-1 below. All wastewater should pass through a 3mm (or less) screening device before introducing into the membrane tank. Large solids may damage the membrane surfaces.

If anti-foaming agents are to be added to the membrane tank, use only alcohol based anti-foaming products. Do not use silicone-based anti-foaming agent which may cause choking of membrane pores.

* Recommended: *Kurita Water Industries “Kuriless 653”*
Schill & Seilacher “Structol SB2032”

The operating conditions may deviate from these standard conditions, depending on condition of the sludge, raw water quality, and/or other given operating conditions.

Table VII-1 Standard Operating Conditions for “NHPA Series”

Parameter	Unit	Operating condition	
MLSS	mg/L	7,000 - 18,000	
Sludge viscosity*	mPa·s	Not higher than 100 ** Not higher than 250 ***	
DO	mg/L	1.0 or more	
pH	-	6 - 8	
Liquid temperature	deg C	15 - 40	
Scouring air flow rate	NHPA050-1C	NL/min/Module (Cubic feet/min/ Module)	430 (15)
	NHPA100-1C		870 (31)
	NHPA150-1C, 2C		1,300 (46)
	NHPA150-3C, 4C		1,500 (53)

* Measured by single cylinder rotary viscometer.

** B type viscometer, e.g. VT-03F by Rion Co., Ltd at 62.5 rpm.

*** C type viscometer, e.g. TVC-10 by Toki Sangyo Co., Ltd at 20 rpm.

**WARNING**

Do not use the filtrate water for drinking.

**WARNING**

Analyze the quality of the filtrate water to ensure that the water quality meets the intended purpose before actual use.

**CAUTION**

Do not use chemicals, toxic agents, oils, or other substances that can adversely affect the condition of activated sludge.

**CAUTION**

Avoid abrupt changes in pH, temperature, trans-membrane pressure, or any other conditions even if they are within the standard operating conditions (Table VII-1).

**CAUTION**

Perform regular inspections of the module. Replace worn parts, as needed, in a timely fashion.

**CAUTION**

If anti-foaming agents are to be added to the membrane tank, use only alcohol based anti-foaming products. Do not use silicone-based anti-foaming agent which may cause choking of membrane pores.

**CAUTION**

Protect the modules from freezing.

2. Operating Parameters

The performance of the “NHPA Series” varies depending on raw water quality and site specific operating conditions. In order to achieve stable “NHPA Series” operation, it is recommended that various operating parameter values be monitored and recorded regularly.

The following operational parameter values should be recorded regularly.

- (1) Scouring air flow rate (blower air flow)
- (2) Diffusion pressure (blower discharge pressure)
- (3) Filtrate water flow rate
- (4) Trans-membrane pressure (TMP)
- (5) Liquid temperature in the membrane tank
- (6) DO (dissolved oxygen) concentration in the membrane tank
- (7) pH in the membrane tank
- (8) MLSS in the membrane tank
- (9) Raw water quality (BOD, COD, turbidity, T-N, T-P, etc.)
- (10) Filtrate water quality (BOD, COD, turbidity, T-N, T-P, TSS etc.)
- (11) Excess-sludge discharge rate
- (12) Sludge viscosity
- (13) Sludge filterability

Preferable recording frequencies are;

- Every five (5) minutes for on-line instruments
- Every day for off-line instruments and sludge properties
- Every week for water quality analysis

3. Basic Control Philosophy

Presented below is the point of the generic MBR control philosophy. The actual MBR system control philosophy will be based on the specific site operating conditions.

- (1) **Suction Pump:** The filtrate suction pump should be controlled to operate for intervals of nine (9) minutes on and one (1) minute off. The filtrate suction pump motor should be fitted with a VFD drive. A filtrate flow transmitter should be installed to provide a control signal to the suction pump VFD. The suction pump should be stopped if the liquid level in the membrane tank drops to a predetermined low liquid level. If, at any time, the air supply to the membrane module or RAS (return activated sludge) is interrupted, the suction pump should be stopped. Do not operate the filtrate suction pump on low membrane tank level or high TMP. Once the air supply has been restored the membrane tank and good RAS circulation is observed, delay the activation of the suction pump for one minute to make certain sufficient sludge mixing has taken place prior to restarting the filtration process. The suction pump should always be off when performing air diffuser cleaning.

-
- (2) **Membrane Scouring Blower:** The blower supplying air for membrane scouring should be on continuously. Air flow (and suction pump) should be stopped if the liquid level in the membrane tank falls below the preset low level for a long period or the flow to the membrane tank stops. In such cases the air supply should be applied for five (5) minutes each hour the system is not producing filtrate. This is required to keep the sludge well mixed and in good condition for restarting the filtration process while avoiding too much stress to the membrane elements.
 - (3) **Membrane Tank Water Level:** If the liquid level in the membrane tank reaches the low level, the suction pump and membrane scouring air should be stopped. If the membrane tank reaches high level the wastewater feed supply should be stopped.
 - (4) **TMP:** Two TMP alarms should be incorporated into the MBR control logic. A "HIGH TMP ALARM" should be activated before the TMP increases 5 kPa from the initial TMP value. A "HIGH-HIGH TMP ALARM" which stops filtration should be activated when the TMP reaches 20 kPa.
 - (5) **Air Diffuser Cleaning Valves:** Install the air diffuser valves, automatic actuated valves are recommended, to facilitate automatically controlled operation of the air diffuser cleaning cycles. Air diffuser cleaning should take place at least once every 24 hours of operation.
 - (6) Equalizing/balancing wastewater load in terms of both quality and quantity is quite important for stable operation of MBR. In this regard having equalization tank with mixing equipment is recommended.

4. Daily Inspection

The above Section 2, Chapter VII lists operating parameters that should be monitored. **Daily recording of the values associated with these parameters will be helpful in determining the current condition of the MBR system. Operational data should be analyzed daily to serve as a guide for preventative maintenance.** Take action to correct any unfavorable operational trends before more serious conditions develop. In addition, it is beneficial to inspect all system components for correct and smooth operation on a weekly basis.

(1) Diffused Air Conditions

Check the air flow rate and blower discharge pressure of the air supply line to the MBR air diffuser. Too low of an air flow rate can result in membrane clogging. Too high of an air flow rate can result in element damage. Try and keep the air flow rate per module between recommended ranges. If the recommended air flow rate cannot be achieved, stop filtration and check the air supply piping for leaks, incorrect valve positions, blower inefficiency, or possible air line restrictions. In the case where multiple MBR modules are located in the same tank, check that diffused air is being evenly distributed between each MBR module. If uneven air distribution is observed, conduct an air diffuser cleaning as described in Section 2, Chapter VIII.



If the scouring air flow rate drops or becomes extremely irregular or if air supply is stopped, then immediately stop filtration to prevent membrane clogging.

(2) Trans- Membrane Pressure

Check the trans-membrane pressure (TMP) frequently. When the TMP increases by 5 kPa (50 mbar) at a constant filtrate flow rate, it is time to initiate a membrane element chemical cleaning. A sudden increase in the trans-membrane pressure suggests that the membrane surfaces are clogging. Clogging can be caused by abnormal diffused air distribution, too high flux rate, too high MLSS concentration or deteriorating sludge properties. If TMP values are increasing, check the MBR operating conditions and the biological condition of the sludge. Take necessary actions to correct operating conditions and then perform a chemical cleaning of the elements.

It is advised measuring the TMPs at different flow rates, e.g. 100% flow, 50% flow, and 33% flow, when starting MBR operation after commissioning. This is for checking correct functioning of pressure measurement and head loss at filtrate piping for different flow velocities.

(3) Activated Sludge Characteristics

The activated sludge of the membrane bioreactor should be self-cohesive and free from odor. The color of healthy activated sludge is typically brown, however this color can differ among plants, depending on wastewater composition, organic load, etc. If an unexpected change is observed in sludge characteristics, check current operating conditions such as BOD load, MLSS concentration, DO, pH, temperature, and/or wastewater composition, and take appropriate corrective actions.

(4) Water Temperature

The desirable water temperature is 15 deg C to 40 deg C. If the temperature is out of this range and the activated sludge properties are not optimum, it is recommendable to install a temperature control device to cool or heat the liquid.

(5) DO

The aeration tank and the membrane tank should be kept in an aerobic condition. If DO is less than 1.0 mg/L, take necessary actions such as increasing the air-flow rate of the biological aeration unit, or lowering the sludge concentration by increasing the excess sludge discharge rate. In the case where the air supply for biological aeration requirements and the air piping for membrane scouring comes from the same blower, do not exceed the recommended range of membrane scouring air flow rate to the diffuser. To increase DO concentration of the liquid within the membrane tank, adjust the separate biological aeration system.

(6) pH

The recommended pH range is 6 to 8. If pH is out of this range and the activated sludge properties are not optimum for filtration, adjust the pH by gradually adding acid or alkali.

(7) MLSS

MLSS concentration in the membrane tank is recommended between 7,000 to 18,000 mg/L. If the MLSS is too low, increase the MLSS concentration in the membrane tank by reducing the sludge discharge rate. If the MLSS concentration is too high, check the RAS (return activated sludge) flow rate. If it is determined that the RAS flow rate is too low, increase the RAS flow rate to the proper value. If RAS flow rate is correct, increase excess sludge discharge rate.

(8) Water Levels

Check to confirm that the water levels of the membrane tank are being maintained within the recommended values. If it is determined that the levels are not as per the design, check the followings: level control devices, level control circuits, filtrate pump VFD controls, activated

sludge feed control valve, and membrane flux rate. Take corrective action as necessary.

(9) Sludge Viscosity

It is recommended that the sludge be no higher than 100 MPa.s (measured by B-type viscometer) or 250 MPa.s (measured by C-type viscometer). If the sludge viscosity is too high, check MBR operating conditions and biological conditions such as F/M ratio, and take necessary corrective actions.

(10) Sludge filterability

Paper filtration method is a simple and reliable method to determine the filtration properties of the sludge. See the method described in the attached document. Toray recommends conducting paper filtration test and measurement of TOC and/or turbidity of filtered water routinely. In the case an abrupt decrease in filterability is recorded and/or increase in TOC/turbidity, check the operating and biological conditions, and take appropriate actions.

(11) Pretreatment System

In addition to the operating parameters for the "NHPA Series", check the status of the pretreatment systems (particularly the screening device) frequently. At regular intervals remove any accumulated trash that may accumulate on the screening device.

VIII. MAINTENANCE OF “NHPA SERIES”

1. Maintenance Items and Maintenance Frequency

It is recommended that the following maintenance tasks be performed on a regular basis to maintain optimal performance of the “NHPA Series” module.

- (1) Clean the air diffusers (at least once per 24 hours)
- (2) Perform a chemical cleaning if the currently recorded TMP increases by 5 kPa (50 mbar) from the initially recorded TMP (assuming the filtrate flow rate is the same value) or every six (6) months, whichever comes first.
- (3) Replace filtrate connection tubes connected to the filtrate manifold when they show some deterioration.
- (4) Replace membrane cassettes or element blocks if, after chemical cleaning, filtrate flow or quality cannot be restored.



CAUTION

Be sure to use Toray approved replacement parts.



CAUTION

Contact Toray sales department to obtain information on how to order Toray approved replacement parts.



CAUTION

Make certain the tube is securely attached to the membrane element nozzle when replacing the individual filtrate tubes to the filtrate manifold.



CAUTION

Do not apply excessive force to the nozzle or membrane element when replacing filtrate tubes. Excessive force may result in membrane element/manifold damage.



CAUTION

Once a filtrate tube has been removed or disconnected from either the element nozzle or filtrate manifold, it should be replaced with a Toray approved replacement part. Old filtrate tubes lose their elasticity, and the integrity of the seal can be compromised.



CAUTION

Note that element replacement is admissible only after instruction from Toray service staff or their trained affiliate personnel.

2. Air Diffuser Cleaning

A clogged air diffuser cannot evenly distribute air to the membrane elements resulting in, which causes that solids build up on the membrane element surface, or, in extreme cases, the membrane element gets damage. **It is recommended that the MBR module(s) be equipped with air diffuser cleaning components/valves that can be automatically controlled from the MBR system PLC. Cleaning of the air diffusers should be performed at least once per 24 hours or as needed to maintain even air distribution.** To clean the air diffuser holes, it is necessary to flush the activated sludge through the diffuser holes into the diffuser piping and finally out from the air/sludge discharge nozzles. This is accomplished by supplying air to the diffuser piping in the reverse direction (see below). The flow of air through the diffuser and out the discharge nozzle will create a suction drawing off the sludge into the diffuser piping. This reverse flow of sludge that will remove any accumulated solids clogged in the diffuser holes. The efficiency of the air diffuser cleaning will improve by the reverse procedure of the air flow direction indicated above.

Observe the flow coming out of the discharge nozzles (V2 and V4) when performing an air diffuser cleaning cycle. In some cases, lengthening the duration of the diffuser cleaning cycle can improve the efficiency of the diffuser cleaning cycle.

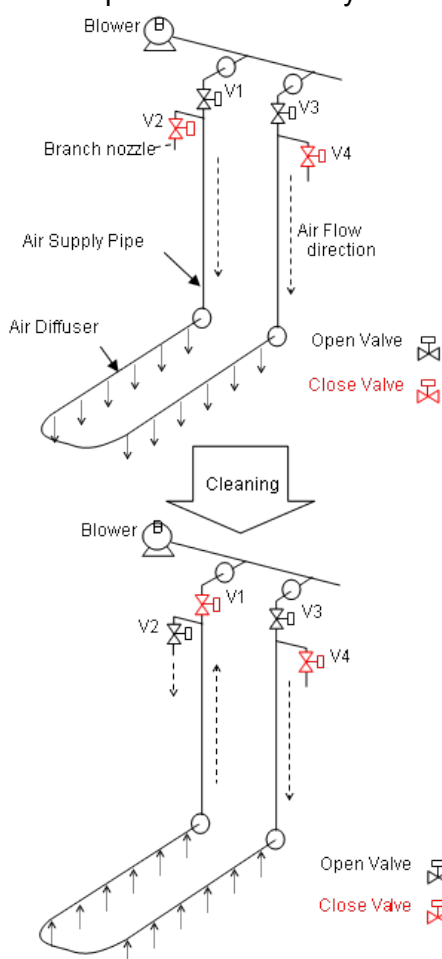

(1) Air Diffuser Cleaning Procedure - Principle

- (i) The filtration must be stopped at first.
- (ii) Open V2 discharge nozzle valve.
- (iii) Close V1 valve. These valve settings will result in liquid sludge flowing through the diffuser holes, into diffuser piping, and the mix of air and sludge will be discharged through V2.
- (iv) Keep V2 valve open for 1 to 5 minutes.
- (v) Open V1 valve, and then close V2 valve.
- (vi) Clean the other line in the same manner as follows.
- (vii) Open V4 discharge nozzle valve.
- (viii) Close V3 valve. These valve settings will result in liquid sludge flowing through the diffuser holes, into diffuser piping, and the mix of air and sludge will be discharged through V4.
- (ix) Keep V4 valve open for 1 to 5 minutes.
- (x) Open V3 valve, and then close V4 valve.
- (xi) Restart the filtration after one minute.

(2) Air Diffuser Cleaning Procedure for Multiple Modules - Practical Design

For multiple module operation, the flushing procedure described in the previous section can be applied for each module, or a more convenient and simple approach is shown in Fig. VIII-1. Each inlet point of the air diffuser should be connected to each of the two air headers, and each header equipped with two valves (automatic valves are strongly recommended) at the inlet point and end point (both higher than water level). The procedure and standard duration time of each action are as follows:

- Flushing: to clean air diffusers, 1 to 5 minutes for each flushing event.
- Purge: to blow out inside header pipes, around 30 seconds for each purge event.

Filtration must be stopped prior to starting the air diffuser cleaning procedure and restarted one minute after air scouring is started. Please take care not to allow sludge to flow toward the blower.

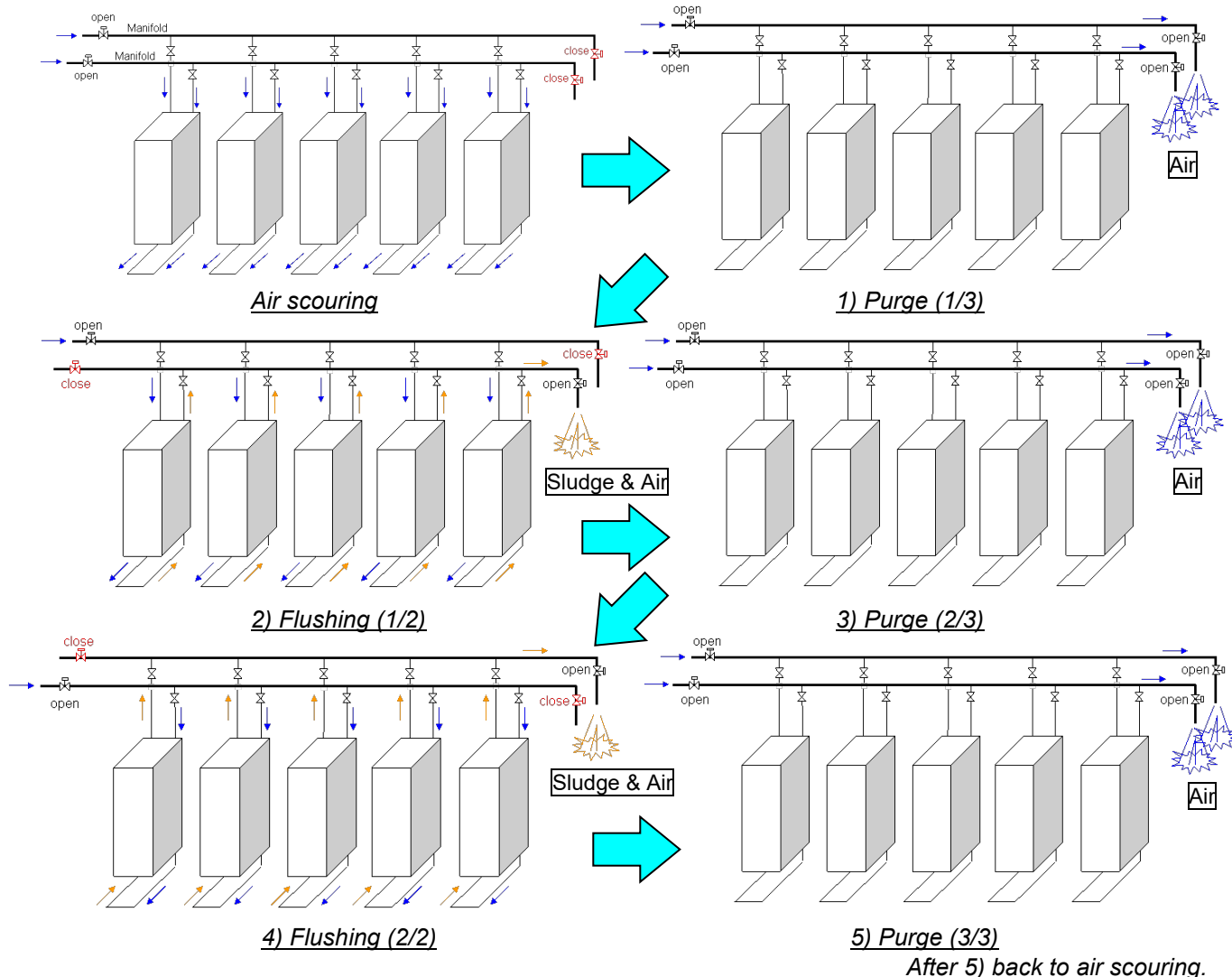

Fig.VIII-1 Air Diffuser Cleaning Procedure for Multiple Modules

3. Chemical Cleaning of Element

Continuous filtration of the sludge will eventually result in plugging of the membrane element pores with trapped solids. Clogging of the membrane pores is indicated by a gradual increase in module TMP. **A chemical cleaning is recommended when any of the following conditions are observed.**

- (1) When the trans-membrane pressure rises by 5 kPa (50 mbar) from its initial operating level (assuming the filtrate water flow rate is the same) or every 6 months of operation, whichever comes first. For example, if an MBR was operated at 7 kPa (70 mbar) TMP in its initial period, then 12 kPa (120 mbar) is the TMP trigger for chemical cleaning.
- (2) When a sudden and significant increase of module TMP is observed. Chemical cleanings are most effective in restoring membrane permeability if the membranes are not severely fouled.
- (3) It is recommended that operations personnel record the time interval required for the TMP to increase by 5 kPa. Premature TMP increases can be the result of less than the optimal operating conditions. This operating procedure is effective to prolong the life of membranes.
- (4) If the membrane permeability is not recovered by a single chemical cleaning, multiple chemical cleaning may be necessary to restore membrane performance.

4. Chemical Agents Available for Chemical Cleaning

Try and select a cleaner that is most appropriate for the suspected foulant when considering chemical cleaning agents. Selecting an inappropriate cleaner can result in further loss in membrane performance or possible membrane damage. Table VIII-1 lists suitable cleaning chemicals and standard cleaning conditions.

Table VIII-1 Cleaning Chemicals and Standard Cleaning Conditions by Contaminant

Contaminant	Chemical	Solution concentration	Amount used	Hold time
Organic matter	Sodium hypochlorite	2,000-6,000 mg/L (Effective chlorine concentration) (10<pH<12)	0.9 L/element	1 to 3 hours
Inorganic matter (either of the two chemicals)	Oxalic acid*	0.5-1.0 wt%	0.9 L/element	1 to 3 hours
	Citric acid	1-3 wt%	0.9 L/element	1 to 3 hours

* Oxalic acid should not be applied when wastewater contains calcium, since calcium oxalate may form on the membrane surface which can choke membrane pores.

5. Handling of Chemical Agents

Follow normal safety precautions when handling potentially harmful chemicals. Avoid direct contact with skin. Take precautions when handling chemicals and wear safety goggles, protective gloves, and other suitable safety gear to avoid injuries. Prior to handling chemicals, read the chemical SDS information to familiarize yourself with dangers and remedies should a chemical spill or contact accident occur.

(1) Sodium Hypochlorite Solution / NaClO

(A) Handling Precautions

- (a) Ventilate well. Avoid heat sources and sparks. Also avoid contact with acids.
- (b) Handle the chemical container with great care. Avoid toppling, bumping, or dragging it.
- (c) Take care not to spill liquid chemicals and avoid breathing in vapors. In the case of dry chemical powders, handle in a manner that minimizes the formation of chemical dust.
- (d) Securely seal all chemical containers after each use.
- (e) Thoroughly wash your hands and face and rinse out your mouth after using chemicals.
- (f) Do not eat or drink anything in the working place except in a designated place.
- (g) Do not bring gloves or other contaminated protectors into the rest area.
- (h) Forbid unauthorized entry to the place where chemicals are handled.
- (i) Wear appropriate protectors to avoid inhalation, eye or skin contact, and direct contact with your clothes.
- (j) Provide local ventilation in the case of handling chemicals indoors.

(B) Storage Precautions

- (a) Store the container in a dark, cold place. Avoid direct sunlight. Firmly seal to prevent direct contact with air.
- (b) Use corrosion-resistant containers for storage.

(2) Oxalic Acid / (COOH)₂

(A) Handling Precautions

- (a) Keep away from strong oxidants and bases.
- (b) Handle the chemical container with great care. Avoid toppling, bumping, or dragging it.
- (c) Take care not to spill liquid chemicals and avoid breathing in vapors. In the case of dry chemical powders, handle in a manner that minimizes the formation of chemical dust.
- (d) Securely seal all chemical containers after each use.

- (e) Thoroughly wash your hands and face and rinse out your mouth after using chemicals.
- (f) Do not eat or drink anything in the working place except in a designated place.
- (g) Do not bring gloves or other contaminated protectors into the rest area.
- (h) Forbid unauthorized entry to the place where chemicals are handled.
- (i) Wear appropriate protectors to avoid inhalation, eye or skin contact, and direct contact with your clothes.
- (j) Provide local ventilation in the case of handling chemicals indoors.

(B) Storage Precautions

- (a) Store the container in a dark, cold place. Avoid direct sunlight. Firmly seal to prevent direct contact with air.
- (b) Use corrosion-resistant containers for storage.

(3) Citric Acid / $\text{HOOCCH}_2\text{C}(\text{OH})(\text{COOH})\text{CH}_2\text{COOH}$

(A) Handling Precautions

- (a) Keep away from strong oxidants and bases.
- (b) Handle the chemical container with great care. Avoid toppling, bumping, or dragging it.
- (c) Take care not to spill liquid chemicals and avoid breathing in vapors. In the case of dry chemical powders, handle in a manner that minimizes the formation of chemical dust.
- (d) Securely seal all chemical containers after each use.
- (e) Thoroughly wash your hands and face and rinse out your mouth after using chemicals.
- (f) Do not eat or drink anything in the working place except in a designated place.
- (g) Do not bring gloves or other contaminated protectors into the rest area.
- (h) Forbid unauthorized entry to the place where chemicals are handled.
- (i) Wear appropriate protectors to avoid inhalation, eye or skin contact, and direct contact with your clothes.
- (j) Provide local ventilation in the case of handling chemicals indoors.

(B) Storage Precautions

- (a) Store the container in a dark, cold place. Avoid direct sunlight. Firmly seal to prevent direct contact with air.
- (b) Use corrosion-resistant containers for storage.

**WARNING**

Chemical agents used for chemical cleaning can be harmful to one's health. Wear protective goggles, protective gloves, and other safety gear when handling chemicals. Make sure to check the details of its material safety data sheet (SDS) beforehand.

**WARNING**

If chemicals come in contact with your skin or clothes, immediately wash the contacted area with a large volume of running water.

**WARNING**

If chemicals splash into your eyes, immediately flush with large volumes of running water and contact a doctor.

**WARNING**

Store chemicals in a dark, cold place free from direct sunlight.

**WARNING**

Use chemical storage tanks constructed of chemically compatible materials to prevent corrosion.

**WARNING**

Never mix sodium hypochlorite with heavy metals or acids. The resulting chemical reaction will generate toxic chlorine gas.

6. Chemical Cleaning Procedure

(1) Element Chemical Cleaning Procedure

To begin the cleaning process slowly inject the chemical via the filtrate water nozzle into the elements until the cleaning solution flows through the membranes. **Do not apply pressure in excessive of 10 kPa (100 mbar) when injecting the cleaning chemicals.** Some recommended cleaning chemical injection methods are shown below.

- a. Chemical cleaning with the chemical tank located at the bottom (Fig.VIII-2)
 - (i) Confirm that the chemical injection valve is closed and that the chemical feed pump is in the off position.
 - (ii) Using the chemical tank, mix the desired amount of chemical solution.
 - (iii) Discontinue the filtration process and associated module aeration. Next close the filtrate water valve.
 - (iv) Start the chemical feed pump and check to make certain the pump is sufficiently primed, and the chemical is being pumped to the elevated cleaning chemical injection tank.
 - (v) Slowly open the chemical injection valve to start injecting the chemical.
 - (vi) After injecting the specified amount of chemicals to the elements, stop the chemical feed pump.
 - (vii) Allow the membrane elements to soak for 1 to 3 hours.
 - (viii) After soaking, close the chemical injection valve, open the filtrate valve, and start the module aeration. Finally, resume normal filtration process.

* *When starting up the MBR after a chemical cleaning, some residual cleaning chemical may be present in the filtrated water for 2 or more filtration cycles. It is recommended that the filtrate flow be directed back into the raw water tank until no residual cleaning chemical is detected. Before directing the filtrate from the raw water tank back to the normal filtrate discharge line, test the filtrate pH and chlorine concentration.*

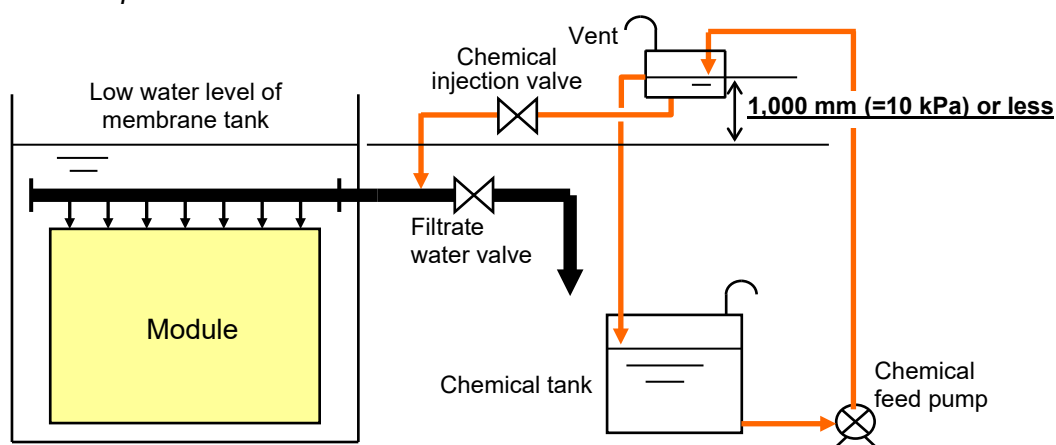

Fig.VIII-2 Chemical Cleaning with Chemical Tank Located at the Bottom

b. Chemical cleaning with the chemical tank located above the membrane tank (Fig.VIII-3)

- (i) Confirm that the chemical injection valve is closed.
- (ii) Using the chemical tank, mix the desired amount of chemical solution.
- (iii) Discontinue the filtration process and associated module aeration. Next close the filtrate valve.
- (iv) Slowly open the chemical injection valve to inject chemicals.
- (v) After injecting the chemical, soak the elements for 1 to 3 hours.
- (vi) Close the chemical injection valve, open the filtrate valve, and start the module aeration. Finally resume the filtration process.

* *When starting up the MBR after a chemical cleaning, some residual cleaning chemical may be present in the filtrated water for 2 or more filtration cycles. It is recommended that the filtrate flow be directed back into the raw water tank until no residual cleaning chemical is detected. Before directing the filtrate from the raw water tank back to the normal filtrate discharge line, test the filtrate pH and chlorine concentration.*

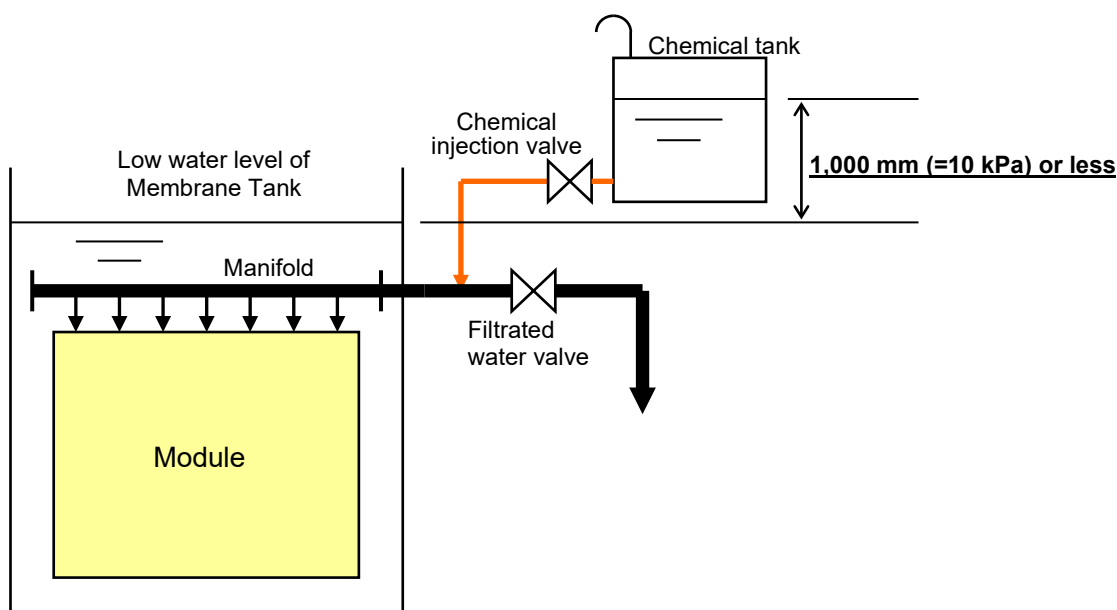

Fig.VIII-3 Chemical Cleaning with Chemical Tank Located above Membrane Tank

c. Chemical cleaning with the chemical feed pump and relief piping (Fig.VIII-4)

- (i) Confirm that the chemical feed pump is in the off position, both the chemical feed valve and the chemical injection valve are in the closed position. To make certain that the filtrate line does not experience too high pressure, confirm that the relief piping is located at the height of 1 m or less from the surface of membrane tank water level.
- (ii) Using the chemical tank, mix the desired amount of chemical solution.

- (iii) Stop the filtration process, stop module aeration, and finally close the filtrate valve.
- (iv) Open the chemical feed valve and start the chemical feed pump.
- (v) Confirm that the outlet of the pressure relief pipe is free of obstructions and that any cleaning solution being discharged is flowing freely back into the chemical tank. If the flow from the relief pipe is excessive, make any necessary adjustments to the chemical pump flow to reduce relief pipe discharge flow.
- (vi) Slowly open the chemical injection valve to start injecting the chemical.
- (vii) After injecting the specified amount of chemicals to the elements, close the chemical injection valve and stop the chemical feed pump.
- (viii) Allow the membrane elements to soak for 1 to 3 hours.
- (ix) After the soaking period close the chemical feed valve, open the filtrate valve, and start aeration. Finally resume the filtration process.

* *When starting up the MBR after a chemical cleaning, some residual cleaning chemical may be present in the filtrated water for 2 or more filtration cycles. It is recommended that the filtrate flow be directed back into the raw water tank until no residual cleaning chemical is detected. Before directing the filtrate from the raw water tank back to the normal filtrate discharge line, test the filtrate pH and chlorine concentration.*

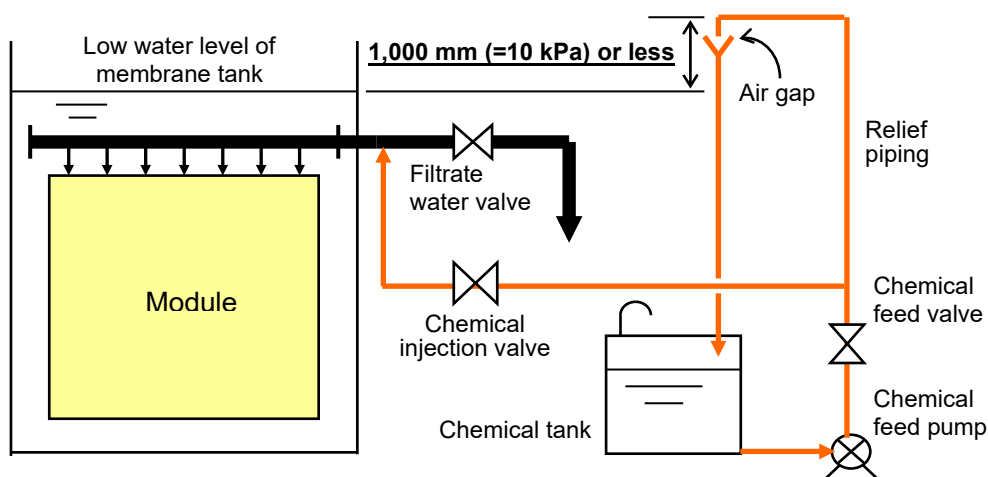

Fig.VIII-4 Chemical Cleaning with the Chemical Feed Pump and Relief Piping



WARNING

Do not attempt to inject chemicals, using a chemical feed pump, without installing a pressure relief pipe and associated air gap. Excess internal element pressure will damage the membrane element.



WARNING

If the flow from the relief pipe is excessive, make any necessary adjustments to the chemical pump discharge flow to reduce relief pipe discharge flow. Use the safety equipment such as goggles and gloves when inspecting discharge piping and making adjustments.

(2) Precautions for Element Chemical Cleaning

- a. **Keep the injecting pressure below 10 kPa (100 mbar).** Avoid direct discharge from the chemical pump to the membrane elements. Too high pressure in the membrane element will cause damage to the membrane. Please note that injecting pressure may increase after injecting half of the chemical.
- b. Make certain the module is completely submerged in the tank prior to injecting any chemicals. The liquid level above the module should be maintained at 500 mm or higher.
- c. Elevated chemical cleaning solution temperatures increase the membrane cleaning effectiveness. However, make certain not to allow the cleaning solution temperatures to exceed 40 deg C. Conversely, lower cleaning solution temperatures reduce the effectiveness of the chemical cleaning process. Try to maintain the cleaning solution temperature as high as possible under 40 deg C.
- d. When starting up the MBR after a chemical cleaning, some residual cleaning chemical may be present in the filtrated water for 2 or more filtration cycles. It is recommended that the filtrate flow be directed back into the raw water tank until no residual cleaning chemical is detected. Before directing the filtrate from the raw water tank back to the normal filtrate discharge line, test the filtrate pH and chlorine concentration.
- e. **If a sodium hypochlorite cleaning is immediately followed by acid cleaning or in reverse order, make certain that these chemicals never come in contact with one another in the cleaning tank or piping.** Mixing of the two chemicals will generate toxic chlorine gas.
- f. If filtrate is used as makeup water for the cleaning solution, there exist the risk of the formation of insoluble calcium compounds when sodium hypochlorite is mixed with the filtrate. If a high calcium concentration is expected in the makeup water, confirm the generation of precipitation by performing a bench-scale sodium hypochlorite addition test. If a whitish precipitate of calcium forms, it is recommended that tap water be used for the makeup water supply instead of filtrate.
- g. As a result of contacting with hypo solution, some activated sludge nearby membrane surface can be destroyed, which leads to a foaming issue. This sludge damage will be recovered in the course of time after operation restart and thus not a big trouble.



Immediately stop the chemical cleaning operation if any of the associated cleaning equipment appears to be malfunctioning.



Never mix sodium hypochlorite with oxalic acid or citric acid. Such mixture generates toxic chlorine gas.



Do not inject any chemical into the membrane directly from the chemical pump discharge. Excessive membrane element internal pressure will damage the element. Be sure to inject chemicals at a pressure less than 10 kPa (100 mbar).



Before starting injecting chemical to elements, confirm that the membrane tank liquid level is more than 500 mm above the top of the module.



To avoid scattering of chemical solution, turn off the air scour during a chemical cleaning.

7. Lifting Procedure

Follow these procedures when lifting the “NHPA Series” modules for maintenance.

- (1) If guide rail system is not installed in the membrane tank, drain the activated sludge from membrane tank.
- (2) Disconnect the manifold from the filtrate water line and disjoint the bolts jointing the element block with the aeration block in case bolts/nuts are applied for connecting both blocks.
- (3) Hook the chain/sling attached with element block to the lifting device, and you can lift up the element blocks using chains/slings. Connected two (2) element-decks can be lifted up at one time.
- (4) **Use guide rails certainly and do not connect three (3) element-decks or more when installing taller module NHPA150-3C and 4C. Also do not lift entire decks at one time. The upper/lower element block must be lifted one by one to avoid distortion or damage to the element block which may cause severe accident. See the instruction below.**

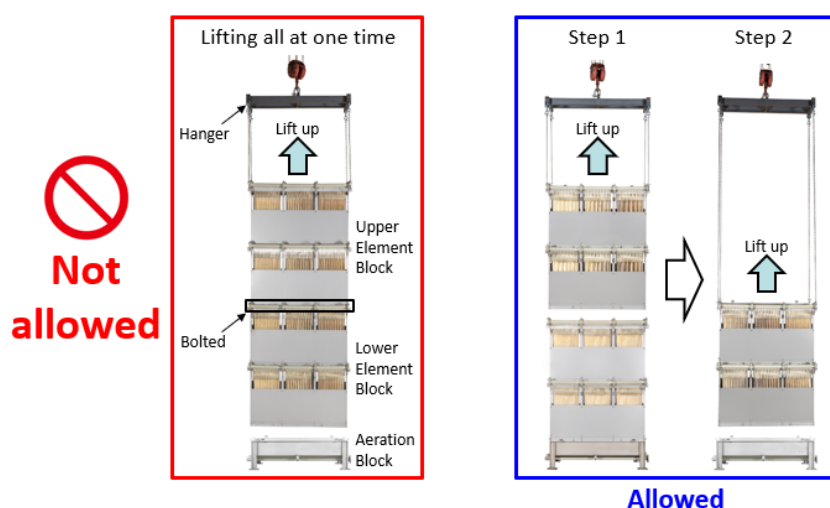

DANGER

Attach chains or slings to the lifting lugs when lifting element-deck, element block or aeration block of “NHPA Series”. Slowly raise the module straight up. Avoid sudden changes in movement to minimize shaking the module. Never allow personnel to stand under the “NHPA Series” during lifting.



DANGER

Never lift or operate the module with worn or damaged parts. Use chains or slings rated for the weight being lifted. Check the condition of each part before lifting.



DANGER

Do not lift upper element block and lower element block at once as one unit when lifting NHPA150-3C or 4C. Lift the upper and lower element block separately.



CAUTION

Wear the appropriate personal protective equipment (e.g. safety gloves) in order not to cut hand on the edge of the module frame.



Keep the membranes wet once they get wet. If the membranes are allowed to dry out, the permeability of the membranes may be permanently reduced.

8. Storing Products after Use

Take the following steps to preserve and store used “NHPA Series” modules.

(1) In case of module storage with sludge inside (without sludge drainage), stop filtration and aeration should be stopped or intermittent e.g. five (5) minutes every hour to agitate and supply minimal DO to the sludge.

Continuous aeration should not be applied from the viewpoint of membrane protection. Also, open air discharge valve on filtrate piping during aeration to avoid the possible air accumulation inside module and subsequent module damage.

(2) For long-term storage of used module (i.e. just for membrane preservation), take following steps.

- Drain the sludge in the membrane tank.
- Using a water hose, wash off the sludge from the modules with clean water. In addition, wash off any remaining sludge on the tank walls. Never use a pressure washer machine on the membrane module and element.
- Fill the membrane tank with clean water until the module is completely covered. Periodically check the water level and add more water if needed to keep the module covered with water. Open air discharge valve before pouring water and keep it open during storage.
- A periodic dosing of the membrane tank storage water to a < 50 ppm concentration of sodium hypochlorite will help inhibit the growth of algae/microorganism during the storage period. Maintaining a hypochlorite concentration higher than 50 ppm for a long-time interval could cause damage to stainless steel components.
- If aeration is required during long-term storage, the aeration cycle should be controlled to aerate only five (5) minutes every hour.

(3) Before re-commissioning of the modules, it is strongly recommended conducting a chemical cleaning of the modules to remove any biofilm growth that may have developed on the membrane surface and piping during the storage period.

If used module (after washing off sludge) must be kept out of water, its duration should be limited within 24 hours and periodic sprinkling of water on the modules (especially membrane surfaces) is needed. In that case, it is required to cover the module (especially top and sides) with a tarp or some other plastic sheet that will protect the module from dust, wind, and direct sunlight.

**CAUTION**

Never use a pressure washer machine when washing the membrane module and element which can cause fatal delamination of membrane element edge.

**CAUTION**

Keep the membranes wet once they get wet. If the membranes are allowed to dry out, the permeability of the membranes may be permanently reduced.

9. Disposing Procedure

Follow these general guidelines when disposing of the membrane after use.

- (1) Clean the membrane module with clean water. After the module has been rinsed off allow the surfaces to dry. Dry surfaces make handling and transport easier.
- (2) Dispose of the module or module components according to local waste disposal regulations. If required, disassemble the module and segregate its components accordingly (e.g. combustible/incombustible).
- (3) Do not incinerate the membrane unless appropriate facilities are available. During the incineration of the membrane materials, harmful Hydrogen Fluoride (HF) gas will be generated. If the membranes are to be incinerated, it is recommended that a professional waste disposal company be hired for the disposal.

**WARNING**

Do not burn the membranes without appropriate facilities since harmful Hydrogen fluoride (HF) gas will be generated. Hire a professional solid waste disposal company to perform the task when disposing of the membrane elements.

IX. REPLACEMENT PARTS LIST

Please contact Toray for the details of the specifications.

(1) NHPA050-1C

Name	Frequency	Type No. of replacement parts	Required Quantity per Module NHPA050-1C
Filtrate Tube	When deterioration detected.	NHP-TUBE-200 (200pcs set)	(50 pcs/unit)
Cassette or Element Block	When filtrate flow or quality cannot be restored after chemical cleaning.	ECS035 (Cassette) or EBL050 (Element Block)	ECS035 x 1 or EBL050 x 1

(2) NHPA100-1C

Name	Frequency	Type No. of replacement parts	Required Quantity per Module NHPA100-1C
Filtrate Tube	When deterioration detected.	NHP-TUBE-200 (200pcs set)	(100 pcs/unit)
Cassette or Element Block	When filtrate flow or quality cannot be restored after chemical cleaning.	ECS035 (Cassette) or EBL100 (Element Block)	ECS035 x 2 or EBL100 x 1

(3) NHPA150-1C

Name	Frequency	Type No. of replacement parts	Required Quantity per Module NHPA150-1C
Filtrate Tube	When deterioration detected.	NHP-TUBE-200 (200pcs set)	(150 pcs/unit)
Cassette or Element Block	When filtrate flow or quality cannot be restored after chemical cleaning.	ECS035 (Cassette) or EBL150 (Element Block)	ECS035 x 3 or EBL150 x 1

(4) NHPA150-2C

Name	Frequency	Type No. of replacement parts	Required Quantity per Module NHPA150-2C
Filtrate Tube	When deterioration detected.	NHP-TUBE-200 (200pcs set)	(300 pcs/unit)
Cassette or Element Block	When filtrate flow or quality cannot be restored after chemical cleaning.	ECS035 (Cassette) or EBL150 (Element Block)	ECS035 x 6 or EBL150 x 2

(5) NHPA150-3C

Name	Frequency	Type No. of replacement parts	Required Quantity per Module NHPA150-3C
Filtrate Tube	When deterioration detected.	NHP-TUBE-200 (200pcs set)	(450 pcs/unit)
Cassette or Element Block	When filtrate flow or quality cannot be restored after chemical cleaning.	ECS035 (Cassette) or EBL150 (Element Block)	ECS035 x 9 or EBL150 x 3

(6) NHPA150-4C

Name	Frequency	Type No. of replacement parts	Required Quantity per Module NHPA150-4C
Filtrate Tube	When deterioration detected.	NHP-TUBE-200 (200pcs set)	(600 pcs/unit)
Cassette or Element Block	When filtrate flow or quality cannot be restored after chemical cleaning.	ECS035 (Cassette) or EBL150 (Element Block)	ECS035 x 12 or EBL150 x 4

X. TROUBLESHOOTING

Most of the troubles in the operation of “NHPA Series” are related to poor membrane scouring aeration, chemical cleaning delay, and inappropriate pretreatment. The following table lists some performance losses, their causes, and possible countermeasures.

Table X-1 Troubleshooting

Problem		Cause	Action
1	The air diffusion flow is below the required level.	The blower is broken.	Stop the filtration and inspect the blower.
		The air diffusers are clogged.	Clean the air diffusers.
2	The air diffusion is uneven in the module or between modules.	The air diffusers are clogged.	Clean the air diffusers.
		The bottom of the element block is stuck with debris.	Check the pretreatment system. Inspect the module. Correct operation and maintenance work of the pretreatment system.
3	The filtrate water flow rate has decreased, or the trans-membrane pressure has increased.	Membrane clogging has got severe.	Conduct chemical cleaning.
		Sludge is accumulated on the membrane surface because of uneven air diffusion	Inspect the blower and clean the air diffusers to improve air diffusion. Conduct chemical cleaning. Remove sludge cake by external cleaning.
		Abnormal properties of sludge have worsened its filterability.	Improve sludge properties. <ul style="list-style-type: none"> • Adjust the excess sludge discharge rate. • Prevent entry of abnormal components, such as oils. • Adjust the BOD load and oxygen supply. • Adjust the raw water quality (add nitrogen, phosphorous, etc.)
		Air is accumulated inside filtrate piping.	Prime the filtrate piping with water. Install air removal equipment such as vacuum pump. Relocate filtrate piping.
4	The concentration of suspended solids in the filtrate water has increased.	Element and/or tube has been broken.	Seal the element and manifold nozzle ^{*1} . Replace the cassette.
		Leakage has occurred in the filtrate water piping.	Inspect the faulty part ^{*2} and correct the fault.
		Germs are generated on the membrane or the filtrate line.	To clean the filtrated water piping, inject a sodium hypochlorite solution with an effective chlorine concentration of 100 to 200 mg/L.

*1: Even if a cause is found in the tube, there is still the possibility of contamination inside the element. Thus, seal the element and manifold nozzle.

*2: To check the piping joints and welds for leakage with a pressure being applied, be careful not to apply pressure to the membrane modules.

XI. WARRANTY POLICY

Full and proper compliance with this Instruction Manual is a mandatory required thing for the claims under the warranty. In case of making a warranty claim, the customer automatically agrees to provide Toray with the information about operation mode, recording performance data of MBR systems.

Please kindly contact Toray if the customer wishes to deviate from any of the procedures or specifications mentioned in this Instruction Manual and request written approval in advance. Otherwise, the customer has risk of invalidation for any warranty claims that they may make in the future.

XII. REFERENCE

Following information is provided upon your request:

- (1) Assembly of Modules
- (2) Assembly of Guide Rail System
- (3) Assembly of Hangers.
- (4) Procedure of Paper filter test.



Toray specializes in the development and manufacture of innovative membrane technologies. We offer an integrated approach using our RO, NF, UF, MBR, and antiscalant products to solve water and process treatment challenges. Contact us today to find out how Toray can help maximize water recovery, achieve high water quality for water reuse, lower energy requirements, and minimize life cycle costs. [TORAY, experts in RO, NF, UF and MBR.](https://www.water.toray)

www.water.toray

'TORAY'

Innovation by Chemistry